

Errata

Title & Document Type: 6104/5A and 6114/5A Operating and Service Manual

Manual Part Number: 5950-5976

Revision Date: June 1972

HP References in this Manual

This manual may contain references to HP or Hewlett-Packard. Please note that Hewlett-Packard's former test and measurement, semiconductor products and chemical analysis businesses are now part of Agilent Technologies. We have made no changes to this manual copy. The HP XXXX referred to in this document is now the Agilent XXXX. For example, model number HP8648A is now model number Agilent 8648A.

About this Manual

We've added this manual to the Agilent website in an effort to help you support your product. This manual provides the best information we could find. It may be incomplete or contain dated information, and the scan quality may not be ideal. If we find a better copy in the future, we will add it to the Agilent website.

Support for Your Product

Agilent no longer sells or supports this product. You will find any other available product information on the Agilent Test & Measurement website:

www.tm.agilent.com

Search for the model number of this product, and the resulting product page will guide you to any available information. Our service centers may be able to perform calibration if no repair parts are needed, but no other support from Agilent is available.

AAHL

***OPERATING AND
SERVICE MANUAL***

**PRECISION POWER SUPPLIES
HP MODELS
6104A, 6114A, 6105A, 6115A**

HP Part No. 5950-5976



**HEWLETT
PACKARD**

AHHL



HEWLETT
PACKARD

**OPERATING AND
SERVICE MANUAL**

PRECISION POWER SUPPLIES

HP MODELS

6104A, 6114A, 6105A, 6115A

HP Part No. 5950-5976

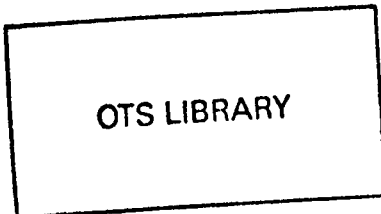

FOR SERIALS 1209A-00051 AND ABOVE*

***For Serials Above 1209A-00051 a change page may be included.**

CALL CENTER LIBRARY



2400013205

CERTIFICATION

Hewlett-Packard Company certifies that this product met its published specifications at time of shipment from the factory. Hewlett-Packard further certifies that its calibration measurements are traceable to the United States National Bureau of Standards, to the extent allowed by the Bureau's calibration facility, and to the calibration facilities of other International Standards Organization members.

WARRANTY

This Hewlett-Packard hardware product is warranted against defects in material and workmanship for a period of one year from date of delivery. HP software and firmware products, which are designated by HP for use with a hardware product and when properly installed on that hardware product, are warranted not to fail to execute their programming instructions due to defects in material and workmanship for a period of 90 days from date of delivery. During the warranty period Hewlett-Packard Company will, at its option, either repair or replace products which prove to be defective. HP does not warrant that the operation for the software firmware, or hardware shall be uninterrupted or error free.

For warranty service, with the exception of warranty options, this product must be returned to a service facility designated by HP. Customer shall prepay shipping charges by (and shall pay all duty and taxes) for products returned to HP for warranty service. Except for products returned to Customer from another country, HP shall pay for return of products to Customer.

Warranty services outside the country of initial purchase are included in HP's product price only if Customer pays HP international prices (defined as destination local currency price, or U.S. or Geneva Export price).

If HP is unable, within a reasonable time, to repair or replace any product to a condition as warranted, the Customer shall be entitled to a refund of the purchase price upon return of the product to HP.

LIMITATION OF WARRANTY

The foregoing warranty shall not apply to defects resulting from improper or inadequate maintenance by the Customer, Customer-supplied software or interfacing, unauthorized modification or misuse, operation outside of the environmental specifications for the product, or improper site preparation and maintenance. NO OTHER WARRANTY IS EXPRESSED OR IMPLIED. HP SPECIFICALLY DISCLAIMS THE IMPLIED WARRANTIES OF MERCHANTABILITY AND FITNESS FOR A PARTICULAR PURPOSE.

EXCLUSIVE REMEDIES

THE REMEDIES PROVIDED HEREIN ARE THE CUSTOMER'S SOLE AND EXCLUSIVE REMEDIES. HP SHALL NOT BE LIABLE FOR ANY DIRECT, INDIRECT, SPECIAL, INCIDENTAL, OR CONSEQUENTIAL DAMAGES, WHETHER BASED ON CONTRACT, TORT, OR ANY OTHER LEGAL THEORY.

ASSISTANCE

The above statements apply only to the standard product warranty. Warranty options, extended support contracts, product maintenance agreements and customer assistance agreements are also available. Contact your nearest Hewlett-Packard Sales and Service office for further information on HP's full line of Support Programs.

SAFETY SUMMARY

The following general safety precautions must be observed during all phases of operation, service, and repair of this instrument. Failure to comply with these precautions or with specific warnings elsewhere in this manual violates safety standards of design, manufacture, and intended use of the instrument. Hewlett-Packard Company assumes no liability for the customer's failure to comply with these requirements.

BEFORE APPLYING POWER.

Verify that the product is set to match the available line voltage and the correct fuse is installed.

GROUND THE INSTRUMENT.

This product is a Safety Class 1 instrument (provided with a protective earth terminal). To minimize shock hazard, the instrument chassis and cabinet must be connected to an electrical ground. The instrument must be connected to the ac power supply mains through a three-conductor power cable, with the third wire firmly connected to an electrical ground (safety ground) at the power outlet. For instruments designed to be hard-wired to the ac power lines (supply mains), connect the protective earth terminal to a protective conductor before any other connection is made. Any interruption of the protective (grounding) conductor or disconnection of the protective earth terminal will cause a potential shock hazard that could result in personal injury. If the instrument is to be energized via an external autotransformer for voltage reduction, be certain that the autotransformer common terminal is connected to the neutral (earthed pole) of the ac power lines (supply mains).

INPUT POWER MUST BE SWITCH CONNECTED.

For instruments without a built-in line switch, the input power lines must contain a switch or another adequate means for disconnecting the instrument from the ac power lines (supply mains).

DO NOT OPERATE IN AN EXPLOSIVE ATMOSPHERE.

Do not operate the instrument in the presence of flammable gases or fumes.

KEEP AWAY FROM LIVE CIRCUITS.

Operating personnel must not remove instrument covers. Component replacement and internal adjustments must be made by qualified service personnel. Do not replace components with power cable connected. Under certain conditions, dangerous voltages may exist even with the power cable removed. To avoid injuries, always disconnect power, discharge circuits and remove external voltage sources before touching components.

DO NOT SERVICE OR ADJUST ALONE.

Do not attempt internal service or adjustment unless another person, capable of rendering first aid and resuscitation, is present.

DO NOT EXCEED INPUT RATINGS.

This instrument may be equipped with a line filter to reduce electromagnetic interference and must be connected to a properly grounded receptacle to minimize electric shock hazard. Operation at line voltages or frequencies in excess of those stated on the data plate may cause leakage currents in excess of 5.0 mA peak.

SAFETY SYMBOLS.



Instruction manual symbol: the product will be marked with this symbol when it is necessary for the user to refer to the instruction manual (refer to Table of Contents).



Indicates hazardous voltages.



or



Indicate earth (ground) terminal.

WARNING

The WARNING sign denotes a hazard. It calls attention to a procedure, practice, or the like, which, if not correctly performed or adhered to, could result in personal injury. Do not proceed beyond a WARNING sign until the indicated conditions are fully understood and met.

CAUTION

The CAUTION sign denotes a hazard. It calls attention to an operating procedure, or the like, which, if not correctly performed or adhered to, could result in damage to or destruction of part or all of the product. Do not proceed beyond a CAUTION sign until the indicated conditions are fully understood and met.

DO NOT SUBSTITUTE PARTS OR MODIFY INSTRUMENT.

Because of the danger of introducing additional hazards, do not install substitute parts or perform any unauthorized modification to the instrument. Return the instrument to a Hewlett-Packard Sales and Service Office for service and repair to ensure that safety features are maintained.

Instruments which appear damaged or defective should be made inoperative and secured against unintended operation until they can be repaired by qualified service personnel.

TABLE OF CONTENTS

| Section | | Page |
|---------|-------------------------------------------------------------------|------|
| 1 | GENERAL INFORMATION | 1-1 |
| | 1-1 Description | 1-1 |
| | 1-4 Models 6104A and 6105A | 1-1 |
| | 1-10 Models 6114A and 6115A | 1-1 |
| | 1-16 Specifications | 1-1 |
| | 1-18 Options | 1-3 |
| | 1-20 Accessories | 1-4 |
| | 1-22 Instrument Identification | 1-4 |
| | 1-25 Ordering Additional Manuals | 1-4 |
| 2 | INSTALLATION | 2-1 |
| | 2-1 Initial Inspection | 2-1 |
| | 2-3 Mechanical Check | 2-1 |
| | 2-5 Electrical Check | 2-1 |
| | 2-7 Repackaging for Shipment | 2-1 |
| | 2-9 Installation Data | 2-1 |
| | 2-11 Location | 2-1 |
| | 2-13 Outline Diagram | 2-1 |
| | 2-15 Rack Mounting | 2-1 |
| | 2-17 Input Power Requirements | 2-1 |
| | 2-20 Power Cable | 2-2 |
| 3 | OPERATING INSTRUCTIONS. | 3-1 |
| | 3-1 Turn-On Checkout Procedures | 3-1 |
| | 3-3 Operating Modes. | 3-2 |
| | 3-5 Normal Operating Mode | 3-2 |
| | 3-8 Constant Voltage. | 3-2 |
| | 3-10 Constant Current. | 3-3 |
| | 3-12 Overvoltage Crowbar Operation | 3-3 |
| | 3-17 Connecting Load | 3-4 |
| | 3-21 Operation Beyond Normal Rated Output | 3-4 |
| | 3-23 Remote Programming, Constant Voltage | 3-4 |
| | 3-29 Remote Programming, Constant Current | 3-5 |
| | 3-36 Remote Sensing (Figure 3-7) | 3-6 |
| | 3-41 Series Operation | 3-7 |
| | 3-43 Auto-Series Operation (Figure 3-9) | 3-7 |
| | 3-47 Parallel Operation | 3-8 |
| | 3-49 Auto-Parallel Operation (Figure 3-11) | 3-8 |
| | 3-52 Auto-Tracking Operation (Figure 3-12). | 3-9 |
| | 3-55 Special Operating Considerations | 3-9 |
| | 3-56 Pulse Loading | 3-9 |
| | 3-58 Output Capacitance | 3-9 |
| | 3-61 Reverse Voltage Loading | 3-10 |
| | 3-63 Reverse Current Loading | 3-10 |
| | 3-65 Gross Current Limit/Automatic Dual-Range Switching | 3-10 |

TABLE OF CONTENTS (Continued)

| Section | | Page |
|---------|---------------------------------------------------------------------------------------|------|
| 4 | PRINCIPLES OF OPERATION | 4-1 |
| | 4-1 Overall Block Diagram Discussion | 4-1 |
| | 4-12 Detailed Circuit Analysis | 4-3 |
| | 4-13 General | 4-3 |
| | 4-15 Voltage Feedback Loop. | 4-3 |
| | 4-18 Current Feedback Loop. | 4-4 |
| | 4-20 Constant Voltage Comparator | 4-4 |
| | 4-27 Constant Current Comparator | 4-5 |
| | 4-32 Driver Circuit | 4-5 |
| | 4-36 Series Regulator | 4-6 |
| | 4-45 Reference Supply. | 4-7 |
| | 4-49 Bias Supply. | 4-8 |
| | 4-51 Overvoltage Protection Crowbar | 4-8 |
| | 4-57 Meter Circuit | 4-9 |
| | 4-61 Additional Protection Features | 4-9 |
| 5 | MAINTENANCE | 5-1 |
| | 5-1 Introduction | 5-1 |
| | 5-3 Test Equipment Required | 5-1 |
| | 5-5 Performance Test. | 5-3 |
| | 5-7 Constant Voltage Tests | 5-3 |
| | 5-42 Constant Current Tests | 5-8 |
| | 5-53 Troubleshooting | 5-11 |
| | 5-58 Overall Troubleshooting Procedure | 5-11 |
| | 5-62 Major Problems | 5-12 |
| | 5-64 Overvoltage Crowbar Checkout and Troubleshooting. | 5-12 |
| | 5-66 Output Current Checkout and Troubleshooting. | 5-12 |
| | 5-68 Specification Problems | 5-14 |
| | 5-70 Repair and Replacement | 5-15 |
| | 5-72 Covers | 5-15 |
| | 5-75 Pushbutton Switch Assembly (6114A/6115A), Meter(s), and Front Panel | 5-15 |
| | 5-77 Rear Heat Sink Assembly. | 5-15 |
| | 5-83 Adjustment and Calibration | 5-15 |
| | 5-85 Meter Zero | 5-15 |
| | 5-87 Gross Current Limit Adjustment | 5-15 |
| | 5-89 Constant Voltage Programming Accuracy | 5-16 |
| | 5-94 Constant Current Programming Accuracy | 5-16 |
| 6 | REPLACEMENT PARTS | 6-1 |
| 7 | CIRCUIT DIAGRAMS AND COMPONENT LOCATION DIAGRAMS | 7-1 |
| | 7-1 Introduction | 7-1 |
| | 7-3 Component Location Diagrams | 7-1 |
| | 7-5 Schematic Diagram. | 7-1 |

SECTION I GENERAL INFORMATION

1-1 DESCRIPTION

1-2 This instruction manual contains operating and service instructions for four Hewlett-Packard precision power supplies. The four models (designated 6104A, 6105A, 6114A, and 6115A) are ideal for applications requiring an accurate, highly stable, and easily settable source of dc voltage or current. All models are completely solid-state and feature constant voltage/constant current operation, automatic dual-range operation, overvoltage crowbar protection, front-panel voltage and current metering, and provisions for remote voltage and current programming. In addition, all models are capable of auto-series, auto-parallel, and auto-tracking operation. Front-panel mounted controls allow current limit and overvoltage trip points to be conveniently set, while OVERVOLTAGE and CURRENT MODE light emitting diodes indicate when the corresponding condition is in effect.

1-3 Additional features and characteristics applicable to specific models are described in the following paragraphs. Section III of this manual covers the use of all controls and indicators and gives procedures for implementing the various operating modes.

1-4 MODELS 6104A and 6105A

1-5 These models employ individual voltage and current meters, and a 10-turn potentiometer for setting output voltage levels. With the exception of some component values and meter scale markings, the two models are physically identical. For improved settability, an optional three-digit decimal voltage control (option 013) is available.

1-6 Model 6104A Output Ratings. The Model 6104A can be operated in either of two ranges: 0 to 20V at 0 to 2A; or 20 to 40V at 0 to 1A. Automatic voltage range crossover occurs if the load current exceeds approximately 1A and the output voltage has been set above 20V.

1-7 The front panel CURRENT control allows the maximum output current to be set to any desired value from 0 amps up to the maximum current rating for the range. Using this control, the power supply can be operated as a constant current source with 0.01% current regulation. The front panel CURRENT MODE indicator lights when either the maximum (gross) current limit is reached, or when the current limit established by the front panel control is

reached. When the indicator is lighted, the output voltage is uncalibrated. However, the front panel voltmeter continues to indicate the output voltage with an accuracy of 2%.

1-8 Model 6105A Output Ratings. The Model 6105A can be operated in either of two ranges: 0 to 50V at 0 to 0.8A; or 50 to 100V at 0 to 0.4A. Automatic voltage range crossover occurs if the load current exceeds approximately 0.4A and the output voltage has been set above 50V.

1-9 The Model 6105A can also be used as a current source, as described in paragraph 1-7.

1-10 MODELS 6114A and 6115A

1-11 These models make use of a front-panel mounted four-digit pushbutton control to increase and decrease output voltage in unit steps. A thumbwheel control is used to set the fifth (or least significant) digit for output voltage accuracy in the fractional millivolt range. A single meter, combining both voltage and current functions, is also located on the front panel. A METER slide switch selects the function to be indicated on the meter. With the exception of some component values and meter scale markings, the 6114A and 6115A are physically identical.

1-12 Model 6114A Output Ratings. The Model 6114A can be operated in either of two ranges: 0 to 20V at 0 to 2A; or 20 to 40V at 0 to 1A. Automatic voltage range crossover occurs if the load current exceeds approximately 1A and the output voltage has been set above 20V.

1-13 The Model 6114A can also be used as a current source, as described in paragraph 1-7.

1-14 Model 6115A Output Ratings. The Model 6115A can be operated in either of two ranges: 0 to 50V at 0 to 0.8A; or 50 to 100V at 0 to 0.4A. Automatic voltage range crossover occurs if the load current exceeds approximately 0.4A and the output voltage has been set above 50V.

1-15 The Model 6115A can also be used as a current source, as described in paragraph 1-7.

1-16 SPECIFICATIONS

1-17 Detailed specifications for all four models are given in Table 1-1.

Table 1-1. Specifications, Models 6104A, 6105A, 6114A, 6115A

| NOTE | | | | | | | | | | | | | | | | |
|-----------------------------------------------------------------------------------------------------------------------------------------------------------------------------------------------------------------------------------------------------------------------------------------------------------|----------------------------------------------------------------------------------------------------------------------------------------------------------------------------------------------------------------------------------------------------------------------------------------------------------------------------------------------------------------------------------------------------------------------------------------------------------------------------------------------------------------------------------|--------------------|--------------------|--------------------|----|------------------|-------------------|-------|--------------------|--------------------|------|-------------------|------------------|-------|--------------------|--------------------|
| Specifications apply to all models, unless otherwise indicated. | | | | | | | | | | | | | | | | |
| GENERAL | | | | | | | | | | | | | | | | |
| INPUT POWER: 104-127 Vac, 48-440Hz, 150VA maximum (Standard) 208-254 Vac, 48-440Hz, 150VA maximum (Switch Selected) | | | | | | | | | | | | | | | | |
| DC OUTPUT: Single output, dual range with automatic cross-over between ranges. <u>Models 6104A & 6114A:</u> 0-20V, 2A/20-40V, 1A <u>Models 6105A & 6115A:</u> 0-50V, 0.8A/50-100V, 0.4A | | | | | | | | | | | | | | | | |
| METERS: <u>Models 6104A and 6105A:</u> Individual voltage and current meters, with $\pm 2\%$ full scale accuracy. <u>Models 6114A and 6115A:</u> Single, dual-function (voltage and current) meter, with $\pm 2\%$ full scale accuracy. | | | | | | | | | | | | | | | | |
| TEMPERATURE RATINGS: Operating: 0 to 55°C. Storage: -40 to +75°C. | | | | | | | | | | | | | | | | |
| COOLING: Convection cooling is employed. The supplies have no moving parts. | | | | | | | | | | | | | | | | |
| DIMENSIONS: See outline diagram, Figure 2-1. | | | | | | | | | | | | | | | | |
| WEIGHT: 17 lbs. (7,7kg.) net. 21 lbs. (9,5kg.) shipping. | | | | | | | | | | | | | | | | |
| CONSTANT VOLTAGE OUTPUT | | | | | | | | | | | | | | | | |
| LOAD REGULATION: For load current change equal to current rating of supply (measured at rear terminals). <u>Models 6104A & 6114A:</u> 0.0005% + 100 μ V <u>Models 6105A & 6115A:</u> 0.0005% + 50 μ V | | | | | | | | | | | | | | | | |
| LINE REGULATION: For a $\pm 10\%$ change in line voltage from nominal value (115 Vac or 230 Vac). <u>Models 6104A & 6114A:</u> 0.0005% + 40 μ V <u>Models 6105A & 6115A:</u> 0.0005% + 100 μ V | | | | | | | | | | | | | | | | |
| RIPPLE AND NOISE: 40 μ Vrms/100 μ V p-p (up to 20MHz) at any line voltage and under any load condition within rating. | | | | | | | | | | | | | | | | |
| TEMPERATURE COEFFICIENT: Output voltage change per degree Centigrade change in ambient following 30-minute warm up. <u>Model 6104A:</u> 0.005% + 25 μ V <u>Model 6105A:</u> 0.005% + 50 μ V <u>Model 6114A:</u> 0.001% + 15 μ V <u>Model 6115A:</u> 0.001% + 15 μ V | | | | | | | | | | | | | | | | |
| DRIFT: Total voltage drift over 8-hour interval under constant line, load, and ambient following a 30-minute warm up. Conditions must be held constant during warm up. <u>Models 6104A & 6105A:</u> 0.005% + 50 μ V ** <u>Models 6114A & 6115A:</u> 0.0015% + 15 μ V * | | | | | | | | | | | | | | | | |
| TRANSIENT RECOVERY TIME: Less than 50 μ sec is required for output voltage recovery to within 10mV of the nominal output voltage following a change in output current equal to the current rating of the supply. | | | | | | | | | | | | | | | | |
| OUTPUT IMPEDANCE (typical): Equivalent to a .05m Ω resistor in series with a 3 μ H inductor. | | | | | | | | | | | | | | | | |
| RESOLUTION: Minimum output voltage change obtainable using front panel voltage controls. <u>Model 6104A:</u> 8mV <u>Model 6114A:</u> 200 μ V <u>Model 6105A:</u> 16mV <u>Model 6115A:</u> 200 μ V | | | | | | | | | | | | | | | | |
| OUTPUT VOLTAGE ACCURACY: 0.025% + 1mV, at 23°C \pm 3°C, at any line vol. and load cur. within rating, after 5-min. warm up. | | | | | | | | | | | | | | | | |
| REMOTE RESISTANCE PROGRAMMING: 2000 Ω /V \pm 0.01% Programming Coefficient. | | | | | | | | | | | | | | | | |
| REMOTE VOLTAGE PROGRAMMING: Programming Coefficient: 1V/V Programming Accuracy: Accuracy of remote source, \pm 0.2mV | | | | | | | | | | | | | | | | |
| REMOTE PROGRAMMING SPEED: The maximum time required to non-repetitively program from 0V to within 99.9% of the maximum rated output voltage (up programming), or from the maximum rated output voltage to within 0.1% of that voltage above 0V (down programming). | | | | | | | | | | | | | | | | |
| | <table border="0"> <thead> <tr> <th></th> <th style="text-align: center;"><u>6104A/6114A</u></th> <th style="text-align: center;"><u>6105A/6115A</u></th> </tr> </thead> <tbody> <tr> <td>up</td> <td>60msec (no load)</td> <td>150msec (no load)</td> </tr> <tr> <td>prog.</td> <td>30msec (full load)</td> <td>75msec (full load)</td> </tr> <tr> <td>down</td> <td>600msec (no load)</td> <td>1.5sec (no load)</td> </tr> <tr> <td>prog.</td> <td>30msec (full load)</td> <td>75msec (full load)</td> </tr> </tbody> </table> | | <u>6104A/6114A</u> | <u>6105A/6115A</u> | up | 60msec (no load) | 150msec (no load) | prog. | 30msec (full load) | 75msec (full load) | down | 600msec (no load) | 1.5sec (no load) | prog. | 30msec (full load) | 75msec (full load) |
| | <u>6104A/6114A</u> | <u>6105A/6115A</u> | | | | | | | | | | | | | | |
| up | 60msec (no load) | 150msec (no load) | | | | | | | | | | | | | | |
| prog. | 30msec (full load) | 75msec (full load) | | | | | | | | | | | | | | |
| down | 600msec (no load) | 1.5sec (no load) | | | | | | | | | | | | | | |
| prog. | 30msec (full load) | 75msec (full load) | | | | | | | | | | | | | | |

Table 1-1. Specifications, Models 6104A, 6105A, 6114A, 6115A (continued)

| | |
|-----------------------------------------------------------------------------------------------------------------------------------------------------------------------------------------------------------------------------------------------------------------------------------------------------------------------------------------------------------------------------------------------------------------------------------------------------------------------------------------------------------------------------------------------------------------------------------------------------------------------------------------------------------------------------------------------------------------------------------------------------------------------------------------------------------------------------------------------------------------------------------------------------------------------------------------------------------------------------------------------------------------------------------------------|-------------------------------------------------------------------------------------------------------------------------------------------------------------------------------------------------------------------------------------------------------------------------------------------------------------------------------------------------------------------------------------------------------------------------------------------------------------------------------------------------------------------------------------------------------------------------------------------------------------------------------------------------------------------------------------------------------------------------------------------------------------------------------------------------------------------------------------------------------------------------------------------------------------------------------------------------------------------------------------------------------------------------------------------------------------------------------------------------------------------------------------------------------------------------------------------------------------------------------------------------------------------------|
| <p>OVERVOLTAGE CROWBAR PROTECTION: Trip Voltage Range (approximate): 0.5V to 10% above rated output voltage of supply. Margin: Minimum 2% + 0.5V above output voltage to prevent false activation.</p> <p>DC OUTPUT ISOLATION: Supply may be floated at up to 300V above ground.</p> <hr/> <p style="text-align: center;">CONSTANT CURRENT OUTPUT</p> <hr/> <p>LOAD REGULATION: 0.01% + 500μA for load voltage change equal to the voltage rating of the supply.</p> <p>LINE REGULATION: For a \pm10% change in line voltage from nominal value (115 Vac or 230 Vac). <u>Models 6104A & 6114A:</u> 0.005% + 40μA <u>Models 6105A & 6115A:</u> 0.005% + 20μA</p> <p>RIPPLE AND NOISE: 200μA rms/1mA p-p at any line voltage and under any load condition within rating.</p> | <p>TEMPERATURE COEFFICIENT: Output change per degree Centigrade change in ambient following 30-minute warm up. <u>Models 6104A & 6114A:</u> 0.02% + 50μA <u>Models 6105A & 6115A:</u> 0.02% + 25μA</p> <p>DRIFT: Total current drift in output over 8-hour interval under constant line, load, and ambient following 30-minute warm up. Conditions must be held constant during warm up. <u>Models 6104A & 6114A:</u> 0.25% + 7mA \ddagger <u>Models 6105A & 6115A:</u> 0.25% + 4mA \ddagger</p> <p>RESOLUTION: Minimum output current change obtainable using front panel current control. <u>Models 6104A & 6114A:</u> 15mA <u>Models 6105A & 6115A:</u> 8mA</p> <p>REMOTE RESISTANCE PROGRAMMING: <u>Models 6104A & 6114A:</u> 500Ω/A \pm 0.5% <u>Models 6105A & 6115A:</u> 1000Ω/A \pm 0.25%</p> <p>REMOTE VOLTAGE PROGRAMMING: <u>Models 6104A & 6114A:</u> 0.5V/A \pm 1% <u>Models 6105A & 6115A:</u> 1V/A \pm 1%</p> |
| <p>* Specified with final decade potentiometer set to zero. If potentiometer is set to value other than zero thermally induced resistance shifts may cause drift of 0.0015% + 200μV.</p> <p>** Potentiometer wiper jump effect may add 5mV (6104A) or 10mV (6105A). When remote programmed, drift is 0.001% + 15μV plus stability of remote programming device.</p> <p>\ddagger When remote programmed, drift is 0.25% + 500μA plus stability of remote programming device.</p> | |

1-18 OPTIONS

1-19 Options are customer-requested factory modifications of a standard instrument. All of the options described below apply to Models 6104A and 6105A. All except option 013 apply to Models 6114A and 6115A.

| <u>Option No.</u> | <u>Description</u> |
|-------------------|------------------------------------------------------------------------------------------------------------------------------------------------------------------------|
| 008 | <u>Ten-turn Output Current Control:</u> Replaces standard single-turn current control to allow greater resolution in setting the output current of supply. |
| 013 | <u>Three Digit Graduated Decadial Voltage Control:</u> Replaces standard 10-turn voltage control of Models 6104A and 6105A for improved output voltage settability. |

| <u>Option No.</u> | <u>Description</u> |
|-------------------|--------------------------------------------------------------------------------------------------------------------------------------------------------------------------------------------------------------------------------------------------------------------------------------------------------------------------------------------------------------------------------------------------------------------------|
| 014 | <u>Three Digit Graduated Decadial Current Control:</u> Includes 10-turn control, replacing standard single-turn current control for greater resolution in setting the output current of supply. |
| 040 | <u>Interfacing for Multiprogrammer Operation:</u> Prepares standard HP power supplies for resistance programming by the 6940A Multiprogrammer or 6941A Multiprogrammer Extender. Operation with either of these instruments requires that the power supply be subjected to (1) Special Calibration, and (2) Protection Checkout. The former procedure insures that the power supply can be accurately set to zero and |

the maximum rated output voltage or current when programmed by the Multiprogrammer; the latter procedure insures that the power supply will not be damaged by the rapid, repetitive programming possible with the Multiprogrammer.

1-20 ACCESSORIES

1-21 The accessories listed in the following chart may be ordered with the instrument or separately from your local Hewlett-Packard sales office (refer to list at rear of manual for addresses).

| <u>HP Part No.</u> | <u>Description</u> |
|--------------------|----------------------------------------------------------------------------------------|
| 5060-8762 | Dual Rack Adapter: Kit for rack mounting one or two supplies in standard 19-inch rack. |
| 5060-8760 | Blank Panel: Filler panel to block unused half of rack when mounting only one supply. |
| 1052A | Combining Case for mounting one or two units in standard 19" rack. |
| 5060-0789 | Cooling kit for above combining case, 115Vac, 50-60Hz. |
| 5060-0796 | Cooling kit for above combining case, 230Vac, 50-60Hz. |

1-22 INSTRUMENT IDENTIFICATION

1-23 Hewlett-Packard power supplies are identified by a three-part serial number. The first part is the power supply model number. The second part is the serial number prefix, consisting of a number-letter combination denoting the date of a significant design change and the country of manufacture. The first two digits indicate the year (12 = 1972, 13 = 1973, 20 = 1980, etc); the second two digits indicate the week (01 through 52); and the letter "A", "G", "J", or "U" designates the U.S.A., West Germany, Japan, or the United Kingdom, respectively, as the country of manufacture. The third part is the power supply serial number; a different 5-digit sequential number is assigned to each power supply, starting with 00101.

1-24 If the serial number prefix on your unit does not agree with the prefix on the title page of this manual, change sheets supplied with the manual or manual backdating changes in Appendix A define the differences between your instrument and the instrument described by this manual.

1-25 ORDERING ADDITIONAL MANUALS

1-26 One manual is shipped with each instrument. Additional manuals may be purchased from your local Hewlett-Packard field office (see list at rear of this manual for addresses). Specify the model number, serial number prefix, and HP part number shown on the title page.

SECTION II INSTALLATION

2-1 INITIAL INSPECTION

2-2 Before shipment, this instrument was inspected and found to be free of mechanical and electrical defects. As soon as the instrument is received, proceed as instructed in the following paragraphs.

2-3 MECHANICAL CHECK

2-4 If external damage to the shipping carton is evident, ask the carrier's agent to be present when the instrument is unpacked. Check the instrument for external damage such as broken controls or connectors, and dents or scratches on the panel surfaces. If the instrument is damaged, file a claim with the carrier's agent and notify your local Hewlett-Packard Sales and Service Office as soon as possible (see list at rear of this manual for addresses).

2-5 ELECTRICAL CHECK

2-6 Check the electrical performance of the instrument as soon as possible after receipt. Section V of this manual contains performance check procedures which will verify instrument operation within the specifications stated in Table 1-1. This check is also suitable for incoming quality control inspection. Refer to the inside front cover of the manual for the Certification and Warranty statements.

2-7 REPACKAGING FOR SHIPMENT

2-8 To insure safe shipment of the instrument, it is recommended that the package designed for the instrument be used. The original packaging material is reusable. If it is not available, contact your local Hewlett-Packard field office to obtain the materials. This office will also furnish the address of the nearest service office to which the instrument can be shipped. Be sure to attach a tag to the instrument specifying the owner, model number, full serial number, and service required, or a brief description of the trouble.

2-9 INSTALLATION DATA

2-10 The instrument is shipped ready for bench operation. It is necessary only to connect the instrument to a source of power and it is ready for operation.

2-11 LOCATION

2-12 This instrument is convection cooled. Sufficient space should be allotted so that a free flow of cooling air can reach the top and rear of the instrument when it is in operation. It should be used in an area where the ambient temperature remains between 0°C and +55°C.

2-13 OUTLINE DIAGRAM

2-14 Figure 2-1 illustrates the outline shape and dimensions of Models 6104A, 6105A, 6114A, and 6115A.

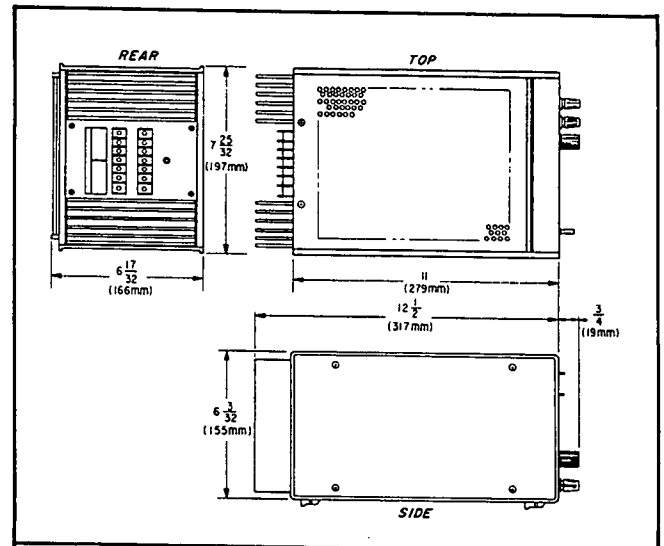

Figure 2-1. Outline Diagram

2-15 RACK MOUNTING

2-16 The Model 6104A, 6105A, 6114A, and 6115A power supplies may be rack mounted using either the dual rack adapter kit or the combining case (with appropriate cooling kit) described in paragraph 1-20. The necessary installation instructions are provided with the accessories.

2-17 INPUT POWER REQUIREMENTS

2-18 Models 6104A, 6105A, 6114A, and 6115A may be operated continuously from either a nominal 120 volt or 240 volt, 48-440Hz power source. A two-position selector switch (⬆) located within the a-c power module on the rear panel selects the power source. Before connecting the instrument to

the power source, check that the selector switch setting matches the nominal line voltage of the source. If required, move the switch to the other position. Note that the power cable must be removed, the plastic door on the power module must be moved aside, the fuse extractor must be pulled outward and the fuse must be removed in order to gain access to the selector switch.

2-19 When the instrument leaves the factory, the proper fuse is installed for 115 volt operation. An envelope containing a fuse for 230 volt operation is attached to the instrument. Make sure that the correct fuse is installed if the position of the slide switch is changed (2A for 115 volt operation, and 1A for 230 volt operation).

2-20 POWER CABLE

2-21 To protect operating personnel, the National Electrical Manufacturers' Association (NEMA) recommends that the instrument panel and cabinet be grounded. This instrument is equipped with a three conductor power cable. The third conductor is the ground conductor and when the cable is plugged into an appropriate receptacle, the instrument is grounded. The offset pin on the power cable's three-prong connector is the ground connection.

2-22 To preserve the protection feature when operating the instrument from a two-contact outlet, use a three-prong to two-prong adapter and connect the green lead on the adapter to ground.

SECTION III OPERATING INSTRUCTIONS

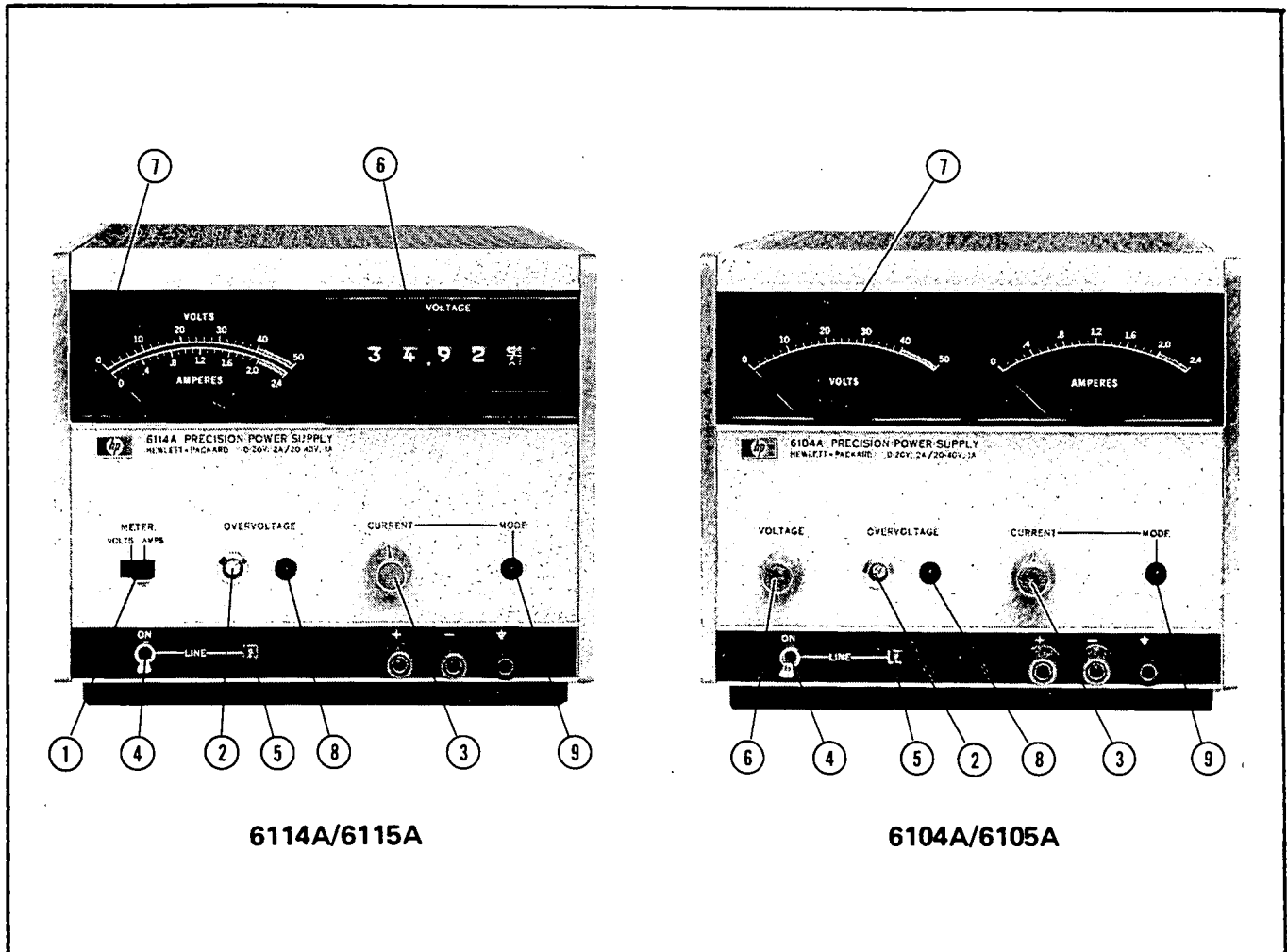

Figure 3-1. Operating Controls and Indicators

3-1 TURN-ON CHECKOUT PROCEDURES

3-2 The following checkout procedure describes the use of the front panel controls and indicators (Figure 3-1) for either the dual meter, ten-turn VOLTAGE control supplies (the 6104A or 6105A) or the single meter, pushbutton VOLTAGE control supplies (the 6114A or 6115A). The checkout procedures ensure that the power supply is operational.

- a. For the 6114A/6115A, set meter switch ① to VOLTS (there is no meter switch on the 6104A or 6105A).
- b. Rotate OVERVOLTAGE (crowbar) control ② (screwdriver adjust) fully clockwise; and rotate CURRENT control ③ to middle of range.

- c. Set LINE switch ④ to ON and observe that indicator ⑤ lights.
- d. Adjust VOLTAGE control ⑥ through the entire output voltage range as indicated on meter ⑦. Adjust output for desired operating voltage.

NOTE

To increase the 6114A/6115A output voltage, depress the pushbutton switch above the associated digit. To decrease the voltage, depress the pushbutton switch below the associated digit. Fine output voltage adjustment is provided by the millivolt digit thumbwheel potentiometer.

e. To ensure that the overvoltage crowbar circuit is operational, rotate the OVERVOLTAGE control counterclockwise until the supply crowbars. Output voltage will fall to approximately one volt and the OVERVOLTAGE and CURRENT MODE indicators (⑧ and ⑨ , respectively) will light.

f. To deactivate the crowbar, return the OVERVOLTAGE control to maximum clockwise position and turn off supply. Turn supply back on and output voltage should again be value obtained in step (d).

g. To checkout the constant current circuit, first turn off supply. Short circuit front panel output terminals (+ to -). On the 6114A or 6115A supplies set meter switch to AMPS. Turn on the supply; CURRENT MODE indicator ⑨ comes on.

h. Adjust CURRENT control through the entire output current range as indicated on meter. Adjust output for desired operating current.

i. Remove short and connect load to output terminals. Note that for maximum load protection by the crowbar, the load should be connected to the rear terminals.

NOTE

The power supply features automatic dual-range operation. If operating voltage and current are both set above the mid-points of supply's voltage and current ratings, the supply will gross current limit if current attempts to exceed one-half the maximum current rating of the supply. If output current increases further, the supply enters the constant current mode in which output voltage is reduced in order to supply the desired current. The VOLTAGE control setting, therefore, is overridden. See paragraph 3-65 for more details.

3-3 OPERATING MODES

3-4 The power supply is designed so that its mode of operation can be selected by making strapping connections between particular terminals on the terminal strips at the rear of the power supply. The terminal designations are stenciled on the power supply above their respective terminals. The operator can ground either the positive or negative terminal or operate the power supply up to 300Vdc off ground (floating). The following paragraphs describe the procedures for utilizing the various operational capabilities of the power supply. A more theoretical description concerning the operational features of this supply is contained in Application Note 90 and in various Tech. Letters. Copies of these can be obtained from your local Hewlett-Packard field office.

3-5 NORMAL OPERATING MODE

3-6 The power supply is normally shipped with its rear terminal strapping connections arranged for constant Voltage/Constant Current, local sensing, local programming, single unit mode of operation. This strapping pattern is illustrated in Figure 3-2.

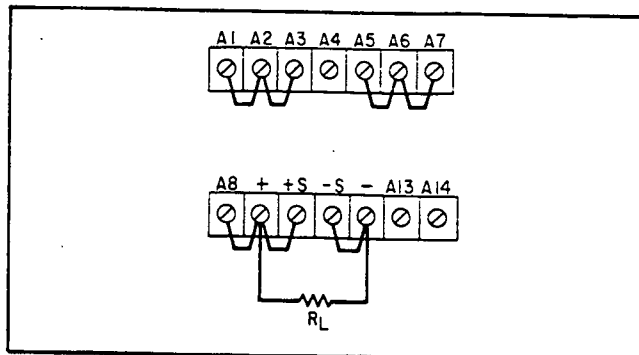

Figure 3-2. Normal Strapping Pattern

3-7 The operator selects either a constant voltage or a constant current output using the front panel controls (for local programming, no strapping changes are necessary). Each supply is rated for two voltage and current ranges as follows:

| Model | Low Range | | High Range | |
|-------------|-----------|---------|------------|---------|
| | Voltage | Current | Voltage | Current |
| 6104A/6114A | 0-20V | 0-2A | 20- 40V | 0-1A |
| 6105A/6115A | 0-50V | 0-.8A | 50-100V | 0-.4A |

When the VOLTAGE and CURRENT settings are within the specified ranges, the constant voltage and constant current modes of operation are selected as described below. If, however, VOLTAGE and CURRENT settings are required that are outside of the specified ranges for normal operation (for instance, the 6104A is set for 30V and 1.5A), the power supply provides automatic dual-range switching if output current attempts to exceed the low range current rating. As current is limited (to approximately 65% of the maximum, low range, rating at nominal line voltage), the VOLTAGE setting is overridden and output voltage is reduced to the low range (approximately 65% of the maximum, high range, voltage rating at nominal line voltage). The supply next enters the constant current mode during which output voltage is reduced in order to supply the desired current. Refer to paragraph 3-65 for more information on how the supply operates to gross current limit and automatically switch ranges.

3-8 CONSTANT VOLTAGE

3-9 To select a constant voltage output, within the normal range ratings of the supply, proceed as follows:

a. Remove load from output terminals; turn on supply and adjust VOLTAGE control for desired

output voltage.

b. Short output terminals and adjust CURRENT control for maximum output current allowable (current limit) as determined by load conditions and voltage range selected in step (a). If a load change attempts to cause the output current to exceed this setting, the power supply will automatically cross-over to constant current mode and output current will be constant at the level set by the CURRENT control. The CURRENT MODE indicator will come on and output voltage will drop proportionately to maintain constant current. In setting the CURRENT control, allowance must be made for high peak current which can cause unwanted cross-over (refer to paragraph 3-56). As discussed above, however, if voltage is set too high with respect to current, the supply will gross current limit and override the VOLTAGE setting, see paragraph 3-65.

3-10 CONSTANT CURRENT

3-11 To select a constant current output, within the normal range ratings of the supply, proceed as follows:

a. Short output terminals and adjust CURRENT control for desired output current.

b. Open output terminals and adjust VOLTAGE controls for maximum output voltage allowable (voltage limit) as determined by load conditions and current selected in step (a). If a load change causes the voltage setting to be exceeded, the power supply will automatically crossover to constant voltage output at the voltage setting and output current will drop proportionately. As discussed above, however, if voltage is set too high with respect to current, the supply will gross current limit and override the VOLTAGE setting, see paragraph 3-65. In setting the voltage limit, allowance must be made for high peak voltages which can cause unwanted crossover (refer to paragraph 3-56).

3-12 OVERVOLTAGE CROWBAR OPERATION

3-13 Trip Point Adjustment. The crowbar trip voltage can be adjusted using the OVERVOLTAGE screwdriver control on the front panel. The trip voltage range of the crowbar is approximately 0.5 to 45Vdc for the 6104A and 6114A supplies and 0.5 to 110Vdc for the 6105A and 6115A supplies. To set the crowbar trip voltage, perform the following procedures:

NOTE

Do not connect a load to the power supply when setting the crowbar trip voltage.

a. Turn OVERVOLTAGE control fully clockwise and turn-on supply.

b. Set output voltage to desired trip voltage. If the desired trip voltage is above 40 volts for the

6114A or 100 volts for the 6115A, perform the next step. If the desired trip setting is within the maximum voltage rating of the 6114A or 6115A supplies or in order to set the trip voltage for the 6104A and 6105A supplies, go on to step (d).

c. If the output of the 6114A or 6115A cannot be set to the desired crowbar trip voltage:

1. Turn off the supply.

2. Disconnect the voltage programming pushbutton switch assembly (two wires connect the switch assembly to Main Power Supply Board A1).

3. Temporarily connect an external resistor (5%, 1/2W) in place of the voltage programming resistor according to the following formula:

$$E_{OUT} = .5mA \times R$$

Where: E_{OUT} is the desired output voltage;

.5mA is the voltage programming current; &

R is the external resistor.

For example, connect a 90K Ω , 5%, 1/2W resistor if the 6114A is to be set to 45V or a 220K Ω , 5%, 1/2W resistor if the 6115A is to be set to 110V.

4. Turn on the supply, the output will be the desired output voltage.

NOTE

The output voltage can be set above the recommended ranges but the crowbar trip voltage may not be adjustable above the recommended ranges.

d. Slowly turn the OVERVOLTAGE control counterclockwise until the crowbar trips: output falls towards 0 volt and OVERVOLTAGE indicator comes on.

e. The crowbar remains activated and the output shorted until the supply is turned off. To reset the crowbar, turn the supply off. If necessary, before turning the supply back on, remove the external resistor installed in step (c) and replace the voltage programming pushbutton switch assembly connections to the A1 board. Next, set output voltage to zero. Turn supply back on and set it to desired output voltage (see next paragraph for an important operating consideration).

3-14 False crowbar tripping must be considered when adjusting the trip point. If the trip voltage is set too close to the operating output voltage, a transient in the output or load can falsely trip the crowbar. It is recommended that the crowbar trip voltage be set higher than the operating output voltage by 2% + 0.5V. For example, the crowbar should be set to trip at a minimum of 31.1Vdc if the output voltage is set to 30Vdc. This operating margin, of course, is not possible if the crowbar is set to trip at or near its lower limit.

3-15 Resetting Crowbar. If the crowbar trips during normal operation (supply output goes to near

zero and OVERVOLTAGE indicator comes on), turn off the supply and then disconnect any load from the power supply. Turn the supply back on and determine if the crowbar again trips. If it does, there is a problem in the power supply. Refer to Section V for troubleshooting procedures that can be used to isolate the cause of the overvoltage condition. If the supply does not crowbar when the load is removed, check the load circuit or the trip point setting.

3-16 Crowbar Terminals. Terminals A13 and A14 at the rear of the supply allow the crowbar trigger to be either monitored by an external circuit or to be used to trip crowbar circuits in other precision power supplies (by interconnecting the A13 and A14 terminals). If precision power supply crowbars are to be interconnected, be sure that all A13 terminals (the positive terminal) are connected and all A14 terminals are connected (see figures 3-9 through 3-11). The crowbar trigger pulse specifications are given below and assume that no supplies are interconnected:

Input Trigger Pulse:

Voltage: 3V minimum, 10V maximum

Width (between 90% point at leading edge and 90% point at falling edge): 10 μ sec minimum.

Output Pulse:

Voltage: 5 \pm 1V

Rise and Fall Time (between 10% and 90% points): 200nsec.

Width: 15 \pm 3 μ sec.

Load Impedance: 10 Ω (min.)

3-17 CONNECTING LOAD

3-18 Each load should be connected to the power supply output terminals (front or rear) using separate pairs of connecting wires. This will minimize mutual coupling effects between loads and will retain full advantage of the low output impedance of the power supply. Each pair of connecting wires should be as short as possible and twisted or shielded to reduce noise pickup. (If a shielded pair is used, connect the shield to ground at the power supply and leave the other end unconnected.)

3-19 If load considerations require that the output power distribution terminals be remotely located from the power supply, then the power supply output terminals should be connected to the remote distribution terminals via a pair of twisted or shielded wires and each load should be separately connected to the remote distribution terminals. For this case, remote sensing should be used. (Refer to paragraph 3-36)

3-20 Positive or negative voltages can be obtained from the supply by grounding either one of the output terminals or one end of the load. Always use two leads to connect the load to the supply, re-

gardless of where the setup is grounded. This will eliminate any possibility of output current return paths through the power source ground. The supply can also be operated up to 300Vdc above ground if neither output terminal is grounded.

3-21 OPERATION BEYOND NORMAL RATED OUTPUT

3-22 The shaded area on the front panel meter face(s) indicates the amount of output voltage or current that may be available in excess of the normal rated outputs (each supply is rated for two voltage/current ranges). Although the supply can be operated in this shaded region without being damaged, it cannot be guaranteed to meet all of its performance specifications. Generally, when operating the supply in this manner, the output is unstable when a load is connected. However, if the line voltage is maintained above its nominal value, the supply will probably operate within the specifications above the rated output. In addition, the supply may be operated slightly above (approximately 130% at nominal line voltage) the voltage/current range specifications (i. e. at about 1.3A up to 40V for the 6104A/6114A or at about 0.52A up to 100V for the 6105A/6115A; or at 2A up to 26V for the 6104A/6114A or .8A up to 65V for the 6105A/6115A). In these operating regions, however, the supply is in gross current limit and certain power supply specifications (such as ripple, etc.) are degraded.

3-23 REMOTE PROGRAMMING, CONSTANT VOLTAGE

3-24 The constant voltage output of the power supply can be programmed (controlled) from a remote location if required. Either a resistance or voltage source can be used as the programming device. The wires connecting the programming terminals of the supply to the remote programming device should be twisted or shielded to reduce noise pickup. The front panel VOLTAGE control is automatically disabled in the following procedures.

3-25 Resistance Programming (Figure 3-3). In this mode, the output voltage will vary at a rate determined by the programming coefficient — 2000 ohms

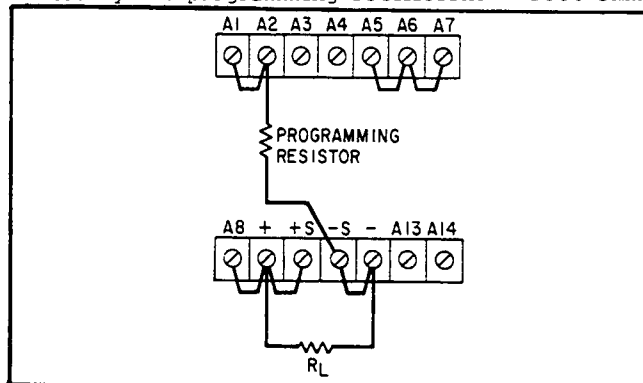

Figure 3-3. Remote Resistance Programming (Constant Voltage)

per Volt (i. e. the output voltage will increase 1 Volt for each 2000 ohms added in series with the programming terminals). The programming accuracy is .01% of the programmed value.

3-26 The output voltage of the power supply should be zero Volts ± 1 millivolt when zero ohms is connected across the programming terminals. The output voltage may be adjusted closer to zero by adjusting potentiometer A2R13 as described in paragraph 5-91.

3-27 To maintain the stability and temperature coefficient of the power supply, use programming resistors that have stable, low noise, and low temperature (at least less than 5ppm per degree centigrade, but preferably 2ppm resistors) characteristics. A switch can be used in conjunction with various resistance values in order to obtain discrete output voltages. The switch should have make-before-break contacts to avoid momentarily opening the programming terminals during the switching interval.

3-28 Voltage Programming, Unity Gain (Figure 3-4). Employ the strapping pattern shown in Figure 3-4 for voltage programming with unity gain. In this mode, the output voltage will vary in a 1-to-1 ratio with the programming voltage (reference voltage) and the load on the programming voltage source will not exceed $1\mu\text{A}$. Impedance matching resistor (R_x) is required to maintain the temperature coefficient and stability specifications of the supply.

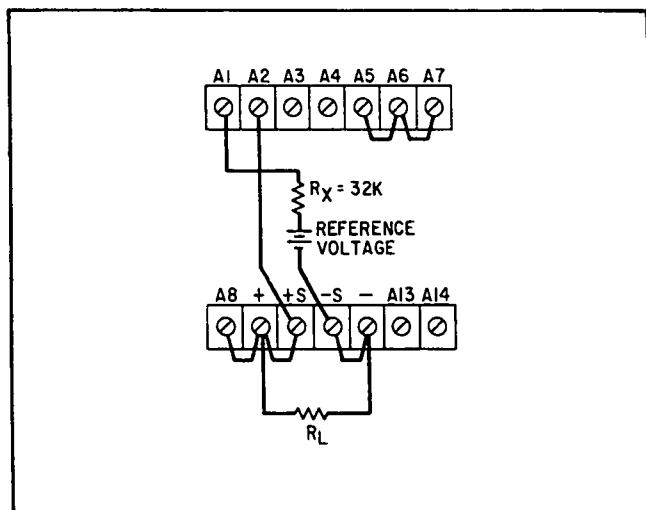

Figure 3-4. Remote Voltage Programming, Constant Voltage

3-29 REMOTE PROGRAMMING, CONSTANT CURRENT

3-30 Either a resistance or a voltage source can be used to control the constant current output of the supply. The CURRENT control on the front panel is automatically disabled in the following procedures.

3-31 Resistance Programming (Figure 3-5). In this mode, the output current varies at a rate determined by the programming coefficient as follows:

| Model | Programming Coefficient |
|-------------|-------------------------|
| 6104A/6114A | 500 ohms/ampere |
| 6105A/6115A | 1,000 ohms/ampere |

The programming accuracy is 0.25% of the programmed value. The output current of the supply when zero ohms is placed across the programming terminals may be set to zero by adjusting A2R12 as discussed in paragraph 5-95.

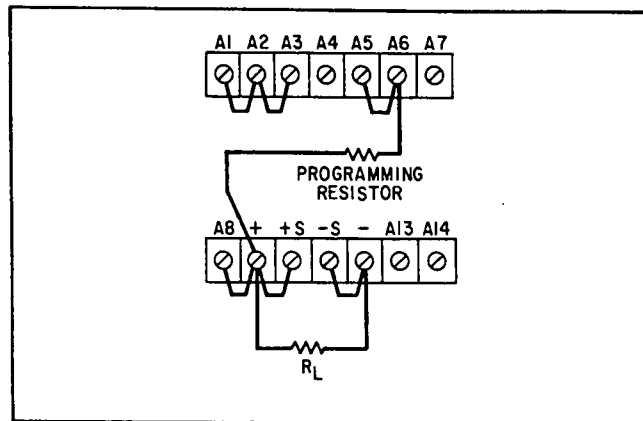

Figure 3-5. Remote Resistance Programming, Constant Current

3-32 Use stable, low noise, low temperature coefficient (at least less than 5ppm per degree Centigrade, but preferably 2ppm) programming resistors to maintain the power supply temperature coefficient and stability specifications. A switch may be used to set discrete values of output current. A make-before-break type of switch should be used since the output current will exceed the maximum rating of the power supply if the switch contacts open during the switching interval.

CAUTION

If the programming terminals (A6 and +) should open at any time during the remote resistance programming mode, the output current will rise to a value that may damage the power supply and/or the load. If, in the particular programming configuration in use, there is a chance that the terminals might become open, it is suggested that a $1.0\text{K}\Omega$ resistor be connected across the programming terminals. Like the programming resistor, this resistor should be a low noise, low temperature coefficient type. Note that when this resistor is used, the resistance value actually programming the supply is the parallel combination of the remote programming resistance and the resistor across the programming terminals.

3-33 Voltage Programming (Figure 3-6). In this mode, the output current will vary linearly with changes in the programming voltage. The programming voltage must not exceed 1.0 volt. Voltage in excess of 1.0 volt will result in excessive power dissipation in the instrument and possible damage.

3-34 The output current varies at a rate determined by the programming coefficient as follows:

| Model | Programming Coefficient |
|-------------|-------------------------|
| 6104A/6114A | 0.5 volts/ampere |
| 6105A/6115A | 1.0 volts/ampere |

The current required from the voltage source will be less than $1\mu\text{A}$. Impedance matching resistor R_X is required to maintain the temperature coefficient and stability specifications of the supply.

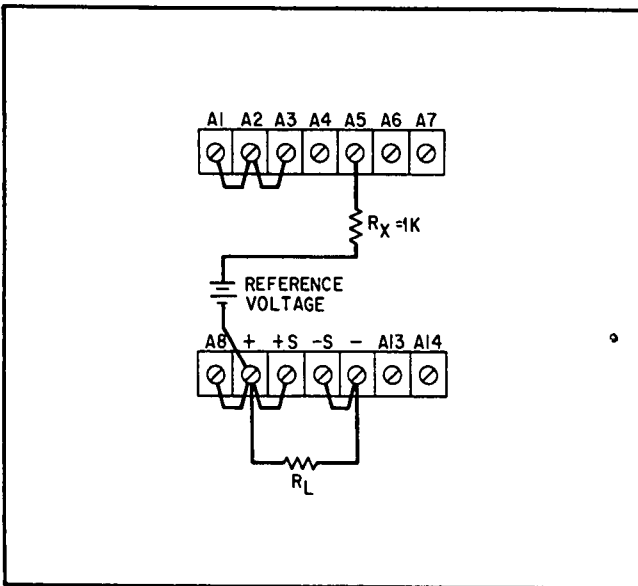

Figure 3-6. Remote Voltage Programming, Constant Current

3-35 The output current of the supply may be adjusted to exactly zero when the external programming voltage is zero by adjusting resistor A2R12 as discussed in paragraph 5-95.

3-36 REMOTE SENSING (Figure 3-7)

3-37 Remote sensing is used to maintain good regulation at the load and reduce the degradation of regulation which would occur due to the voltage drop in the leads between the power supply and the load. Remote sensing is accomplished by utilizing the strapping pattern shown in Figure 3-7. The power supply should be turned off before changing strapping patterns. The leads from the sensing ($\pm S$) terminals to the load will carry much less current than the load leads and it is not required that these leads be as heavy as the load leads. However, they must be twisted or shielded to minimize noise pickup.

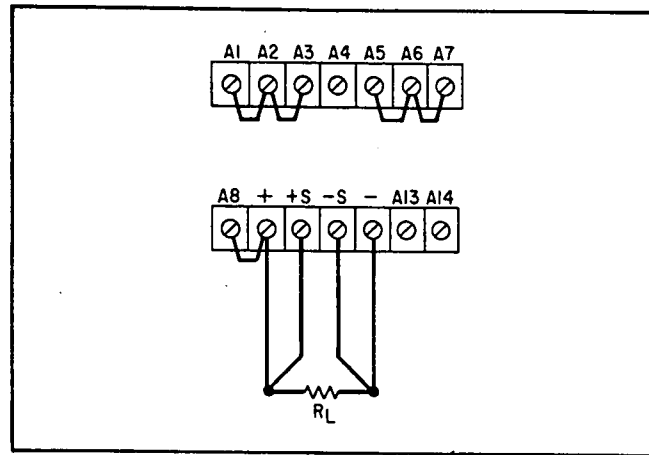

Figure 3-7. Remote Sensing

3-38 For reasonable load lead lengths, remote sensing greatly improves the performance of the supply. However, if the load is located a considerable distance from the supply, added precautions must be observed to obtain satisfactory operation. Notice that the voltage drop in the load leads subtracts directly from the available output voltage and also reduces the amplitude of the feedback error signals that are developed within the unit. Because of these factors it is recommended that the drop in each load lead not exceed 1.0 volt. If a larger drop must be tolerated, please consult an HP Sales Engineer.

NOTE

Due to the voltage drop in the load leads, it may be necessary to readjust the constant current setting in the remote sensing mode.

3-39 Observance of the precautions in paragraph 3-37 will result in a low dc output impedance at the load. However, another factor that must be considered is the inductance of long load leads. This causes a high ac impedance and could affect the stability of the feedback loop seriously enough to cause oscillation. In this case, it is recommended that the following precautions be taken:

- a. Disconnect output capacitor C12 by unstrapping terminal A8.
- b. Connect a capacitor having similar characteristics (approximately the same capacitance, the same voltage rating or greater, and having good high frequency characteristics) across the load using short leads.

3-40 Although the strapping patterns shown in Figure 3-3 through 3-6 employ local sensing, note that it is possible to operate a power supply simultaneously in the remote sensing and constant voltage/constant current remote programming modes.

3-41 SERIES OPERATION

3-42 Normal Series Connections (Figure 3-8). Two or more power supplies can be operated in series to obtain a higher voltage than that available from a single supply. When this connection is used, the output voltage is the sum of the voltages of the individual supplies. Each of the individual supplies must be adjusted in order to obtain the total output voltage. The power supply contains a protective diode connected internally across the output which protects the supply if one power supply is turned off while its series partner(s) is on.

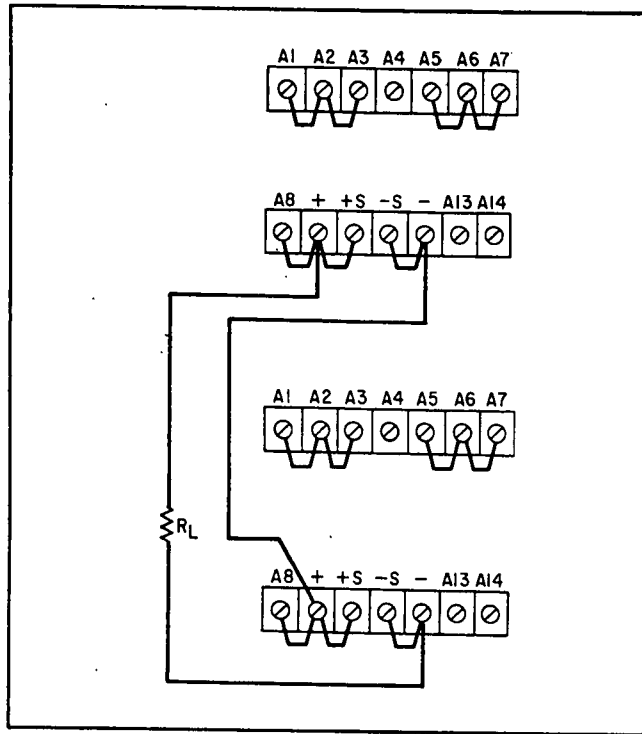

Figure 3-8. Normal Series

3-43 AUTO-SERIES OPERATION (Figure 3-9)

3-44 Two or more power supplies can be operated in Auto-Series to obtain a higher voltage than that available from a single supply. When this connection is used, the output voltage of each slave supply varies in accordance with that of the master supply; thus the total output voltage of the combination is determined by the setting of the front panel VOLTAGE controls on the master. The master supply must be the most positive supply of the series. The output CURRENT controls of all series units are operative and the current limit is equal to the lowest control setting. If any of the output CURRENT controls are set too low, automatic crossover to constant current operation will occur and the output voltage will drop. Remote sensing and programming can be used, though the strapping arrangements shown in Figure 3-9 show local sensing and programming. Notice that the overvoltage

crowbar terminals (A13 and A14) are connected in parallel which means that if any supply crowbars, all supplies will be tripped.

3-45 In order to maintain the temperature coefficient and stability specifications of the power supply, the external resistors (R_X) shown in Figure 3-9 should be stable, low noise, low temperature coefficient (less than 5ppm per degree Centigrade) resistors. The value of R_X is the maximum voltage rating of the master supply divided by the voltage programming current of the slave supply ($1/K_p$ where K_p is the voltage programming coefficient). The power rating of R_X should be at least 10 times the actual power dissipated in the resistor. The voltage contribution of the slave is determined by its voltage control setting.

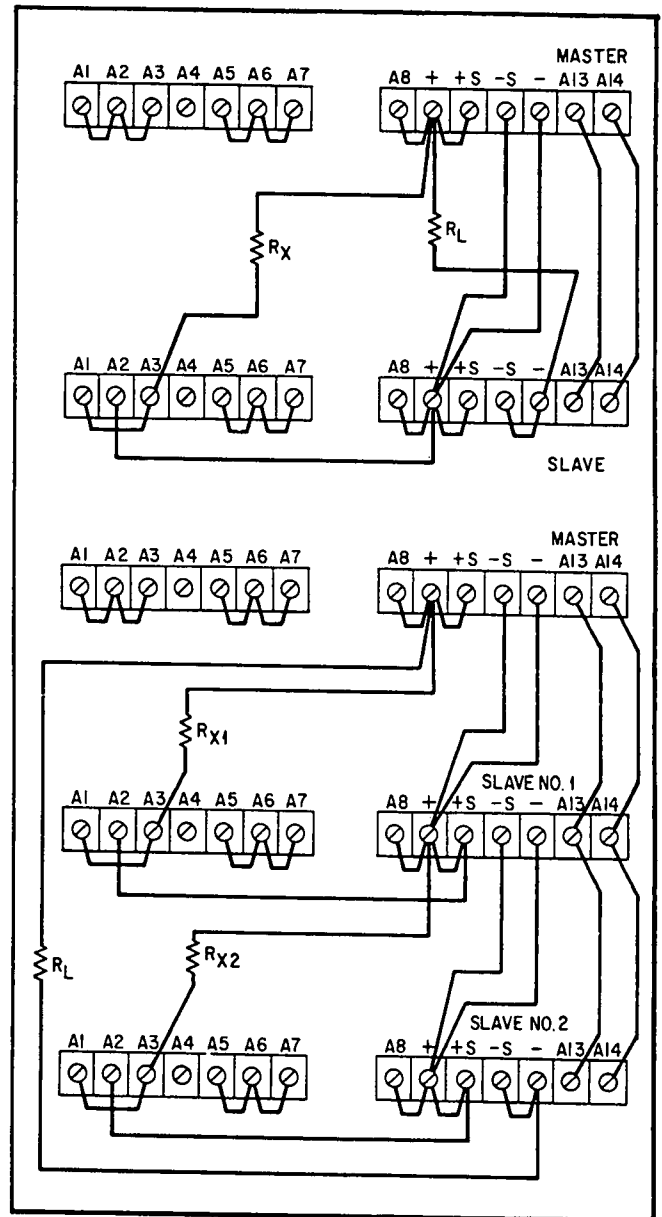

Figure 3-9. Auto-Series Operation, Two and Three Units

3-46 When the center tap of an Auto-Series combination is grounded, coordinated positive and negative voltages result. This technique is commonly referred to as "rubber-banding" and an external reference source may be employed if desired. Any change in the internal or external reference source (e.g. drift, ripple) will cause an equal percentage change in the outputs of both the master and slave supplies. This feature can be of considerable use in analogue computer and other applications, where the load requires a positive and a negative power supply and is less susceptible to an output voltage change occurring simultaneously in both supplies than to a change in either supply alone.

3-47 PARALLEL OPERATION

3-48 Normal Parallel Connections (Figure 3-10). Two or more power supplies can be connected in parallel to obtain a total output current greater than that available from one power supply. The total output current is the sum of the output currents of the individual power supplies. The output CURRENT controls of each power supply can be be separately set. The output voltage controls of one power supply should be set to the desired output voltage; the other power supply should be set for a slightly larger output voltage. The supply set to the lower output voltage will act as a constant voltage source; the supply set to the higher output will act as a constant current source, dropping its output voltage until it equals that of the other supply. The constant voltage source will deliver only that fraction of its total rated output current which is necessary to fulfill the total current demand.

supply. Auto-Parallel operation permits equal current sharing under all load conditions, and allows complete control of the output current from one master power supply. The output current of each slave will be approximately equal to the master's output current regardless of the load conditions. Because the output current controls of each slave are operative, they should be set to maximum to prevent the slave reverting to constant current operation; this could occur if the master output current setting exceeded the slave's.

3-51 Additional slave supplies may be added in parallel with the master/slave combination. All the connections between the master and slave #1 are duplicated between slave #1 and the added

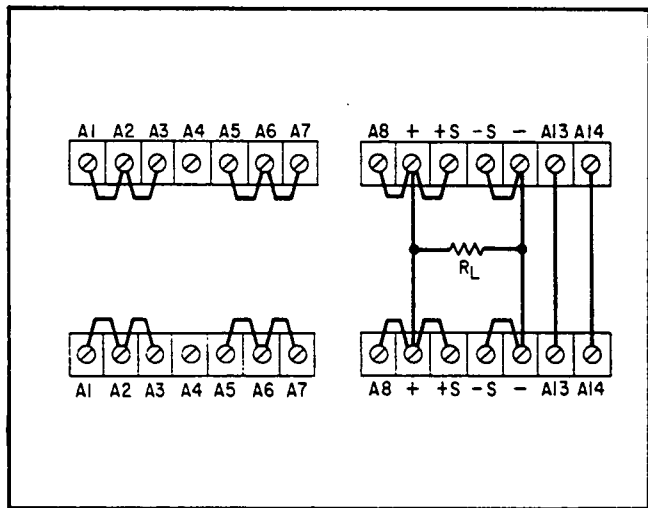

Figure 3-10. Normal Parallel

3-49 AUTO-PARALLEL OPERATION (Figure 3-11)

3-50 Two or more power supplies can be connected in an Auto-Parallel arrangement to obtain an output current greater than that available from one

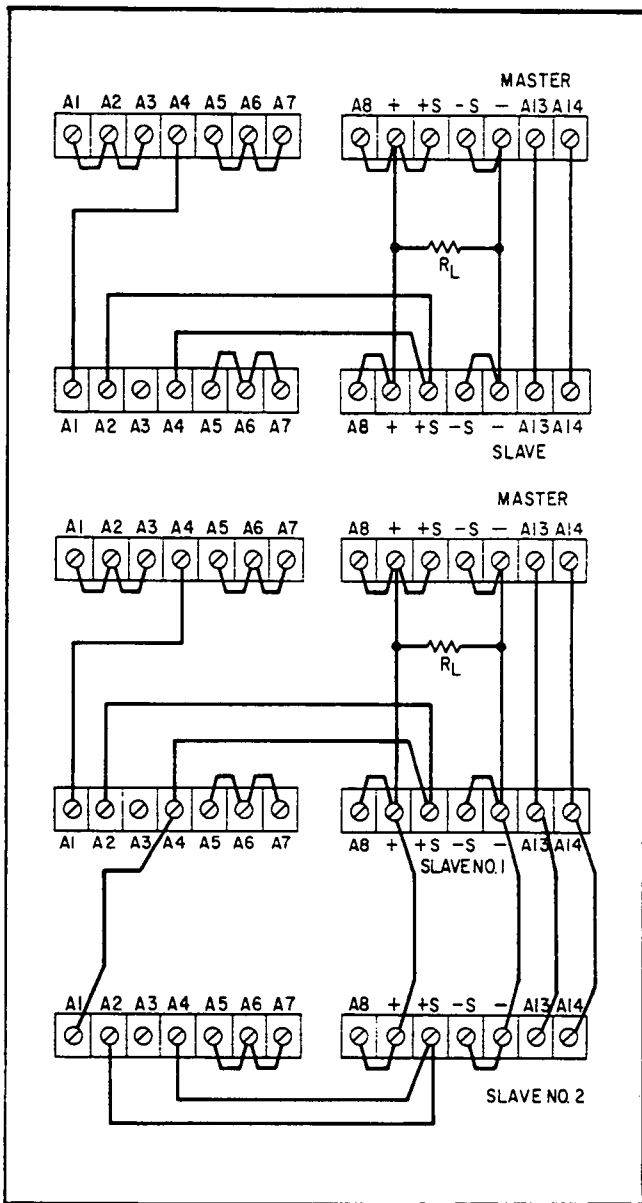

Figure 3-11. Auto-Parallel Operation, Two Units and Three Units

slave supply. In addition, the strapping pattern of the added slave should be the same as slave #1. Remote sensing and programming can be used, though the strapping arrangements shown in Figure 3-11 show local sensing and programming. In order to maintain the temperature coefficient and stability specifications of the power supply, the external resistors (R_X) should be stable, low noise, low temperature coefficient (less than 5ppm per degree Centigrade) resistors. The power rating of R_X should be at least 10 times the actual power dissipated in the resistor.

3-52 AUTO-TRACKING OPERATION (Figure 3-12)

3-53 The Auto-Tracking configuration is used when several different voltages referred to a common bus must vary in proportion to the setting of a particular instrument (the control or master). A fraction of the master's output voltage is fed to the comparison amplifier of the slave supply, thus controlling the slave's output. The master must have the largest output voltage of any power supply in the group. It must be the most positive supply in the example shown in Figure 3-12.

3-54 The output voltage of the slave (E_S) is a percentage of the master's output voltage (E_M), and is determined by the voltage divider consisting of R_X and the voltage control of the slave supply, R_p , where $E_S = E_M [R_p / (R_X + R_p)]$. Remote sensing and programming can be used (each supply senses at its own load), though the strapping patterns given in Figure 3-12 show only local sensing and programming. In order to maintain the temperature coefficient and stability specifications of the power supply, the external resistors (R_X) should be stable, low noise, low temperature coefficient (less than 5ppm/ $^{\circ}$ C) resistors. The value of R_X is found by multiplying the voltage programming coefficient of the slave supply by the desired difference between the master supply voltage and the slave supply voltage.

3-55 SPECIAL OPERATING CONSIDERATIONS

3-56 PULSE LOADING

3-57 When operated within either of the two range ratings, the power supply will automatically cross over from constant voltage to constant current operation, or the reverse, in response to an increase (over the preset limit) in the output current or voltage, respectively. Although the preset limit may be set higher than the average output current or voltage, high peak currents or voltages (as occur in pulse loading) may exceed the preset limit and cause crossover to occur. If this crossover limiting is not desired, set the preset limit for the peak requirement and not the average.

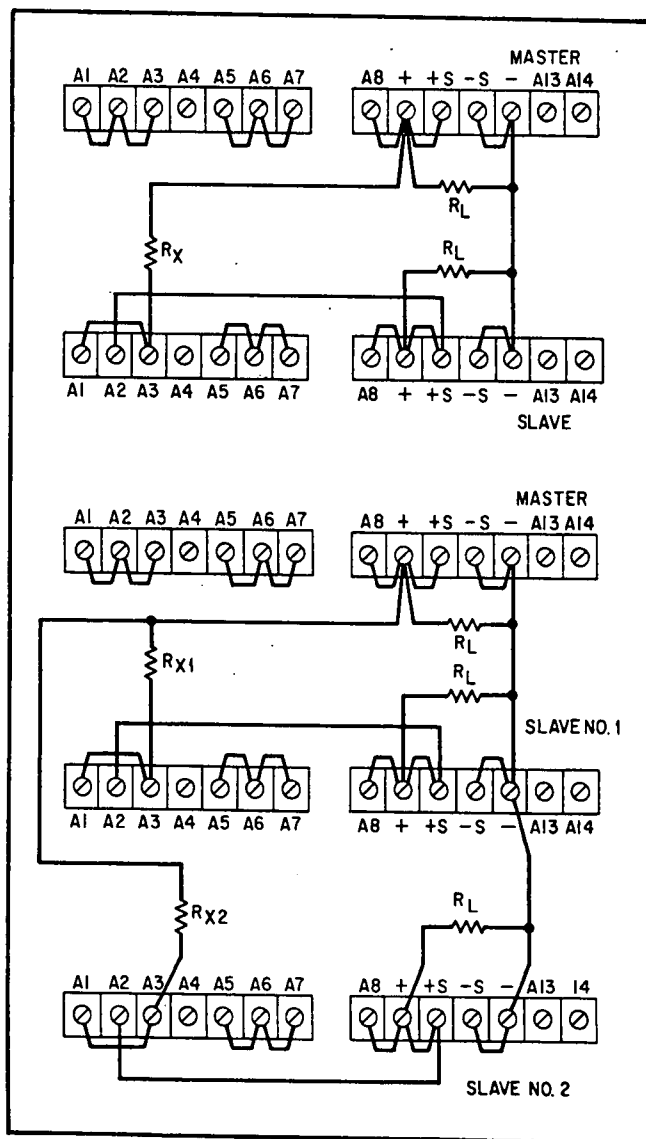

Figure 3-12. Auto-Tracking Operation, Two and Three Units

3-58 OUTPUT CAPACITANCE

3-59 An internal capacitor (C_{12}) connected across the output terminals of the power supply, helps to supply high-current pulses of short duration during constant voltage operation. To reduce current surges, this capacitor can be removed by unstrapping terminal A7. Any capacitance added externally will improve the pulse current capability, but will decrease the safety provided by the constant current circuit. A high-current pulse may damage load components before the average regulator current is large enough to cause the constant current circuit to operate.

3-60 The effects of the output capacitor during constant current operation are as follows:

- a. The output impedance of the power supply decreases with increasing frequency.

b. The recovery time of the output voltage is longer for load resistance changes.

c. A large surge current causing a high power dissipation in the load occurs when the load resistance is reduced rapidly.

3-61 REVERSE VOLTAGE LOADING

3-62 A diode (CR15) is connected across the output terminals. Under normal operating conditions, the diode is reverse biased (anode connected to the negative terminal). If a reverse voltage is applied to the output terminals (positive voltage applied to the negative terminal), the diode will conduct, shunting current across the output terminals and limiting the voltage applied across the output terminals to the forward voltage drop of the diode. This diode protects the series transistors and the output electrolytic capacitors.

3-63 REVERSE CURRENT LOADING

3-64 Active loads connected to the power supply may actually deliver a reverse current to the power supply during a portion of its operating cycle. An external source cannot be allowed to pump current into the supply without loss of regulation and possible damage to the output capacitor. To avoid these effects, it is necessary to preload the supply with a dummy load resistor so that the power supply delivers current through the entire operation cycle of the load device.

3-65 GROSS CURRENT LIMIT/AUTOMATIC DUAL-RANGE SWITCHING

3-66 The power supply can be operated at a CURRENT setting above the high range VOLTAGE rating as given below:

| Model | Low Range | | High Range | |
|-------------|-----------|---------|------------|---------|
| | Voltage | Current | Voltage | Current |
| 6104A/6114A | 0-20V | 0-2.0A | 20-40V | 0-1.0A |
| 6105A/6115A | 0-50V | 0-0.8A | 50-100V | 0-0.4A |

For instance, the 6104A can be operated with the CURRENT control set to 1.5A and the VOLTAGE control set to 30V. However, as shown in Figure 3-13, if the load resistance draws output current above the high range rating (i. e. greater than 1A for the 6104A/6114A or 0.4A for the 6105A/6115A), the power supply enters the gross current limit

region (the CURRENT MODE indicator comes on). In the gross current limit region, output current is maintained up to approximately 130% (at nominal line voltage) of the high range rating (1.3A for the 6104A/6114A or 0.52A for the 6105A/6115A) of the supply while output voltage is maintained at the VOLTAGE setting up to the maximum high range rating. If load resistance continues to change and causes output current to exceed the gross current limit region, however, the supply is automatically switched to the low range and output voltage is reduced to approximately 130% (again, at nominal line voltage) of the low range rating (26V for the 6104A/6114A or 65V for the 6105A/6115A). Of course, at this point the VOLTAGE setting of the supply is overridden. Further load reductions cause the supply to enter the constant current mode and output voltage is further reduced as necessary to supply the necessary output current depending upon load requirements and the CURRENT setting. Notice that when operated in the gross current limit region, the supply's output is uncalibrated and may not meet certain specifications (ripple, etc). Note, further, that if the supply is operated at low or high line, the gross current limit region will vary (decrease at low line and increase at high line).

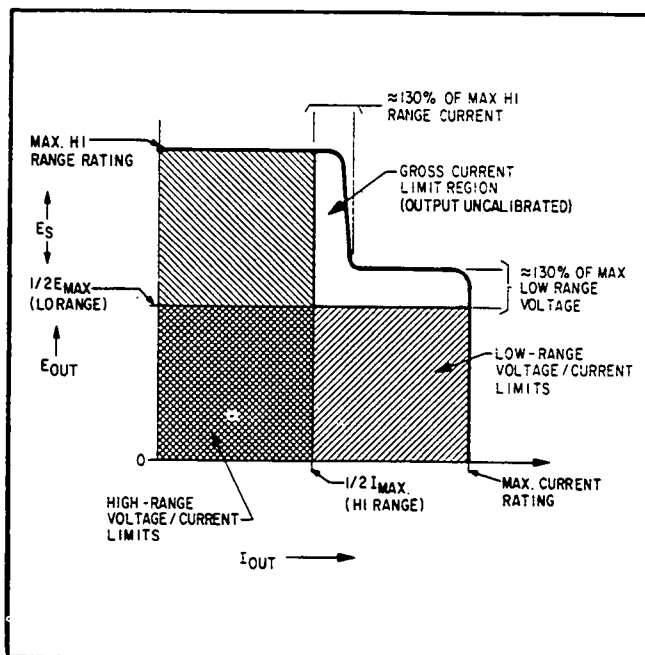

Figure 3-13. Gross Current Limit/Dual-Range Switching

SECTION IV PRINCIPLES OF OPERATION

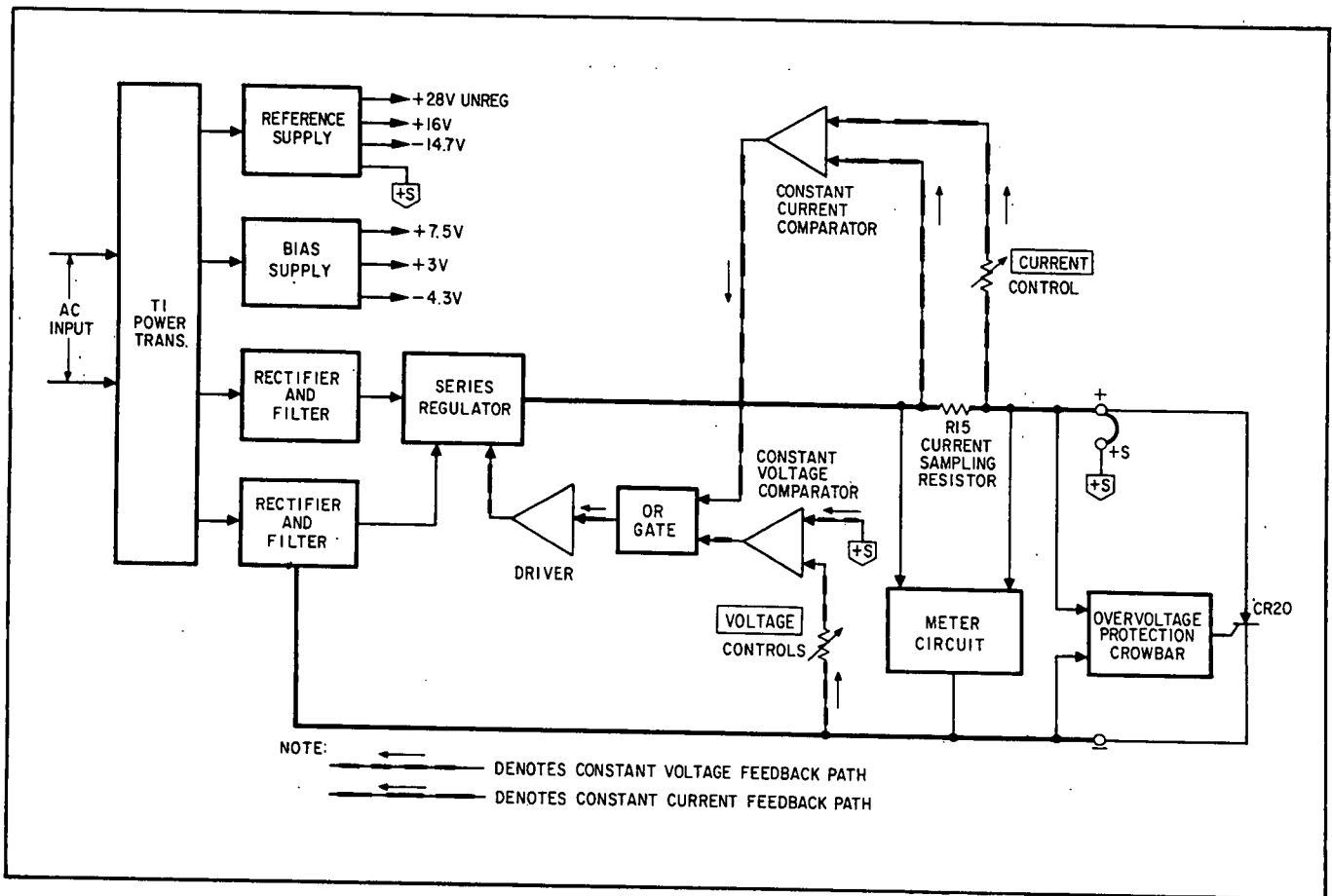

Figure 4-1. Overall Block Diagram

4-1 OVERALL BLOCK DIAGRAM DISCUSSION

4-2 The major circuits of the power supply are shown on the overall block diagram, Figure 4-1. The ac line voltage is first applied to the power transformer, after which it is rectified and filtered. The resulting raw dc is then fed to the series regulator, which varies its conduction to obtain the proper output voltage or current. The series regulator includes a current limit circuit that automatically places the supply in the low voltage range depending upon the output voltage and current settings that have been selected and the output current of the supply. For instance, if the supply is set for high voltage output and high current output and the load attempts to draw current above the high voltage range current specification (that is, above 1A for the 6104A/6114A supplies or above

0.4A for the 6105A/6115A supplies), the series regulator limits the output current and then decreases the output voltage to the low range. When in the low range, the output current is then allowed to reach the CURRENT setting up to the maximum rating of the supply. Notice, further, that dual rectifier-filter circuits are employed to provide a low value of raw dc voltage to the series regulator in order to minimize internal power consumption during low voltage (high current) operation. Each rectifier-filter furnishes most of the raw dc voltage to the regulator during one of the two output voltage, current ranges of the supply.

4-3 The series regulator is part of a feedback loop consisting of the driver and the constant voltage/constant current comparators. When operated within the specified ranges, during constant voltage

operation the constant voltage comparator continuously compares the output voltage of the supply with the drop across the VOLTAGE control. If these voltages are not equal, the comparator produces an amplified error signal which is further amplified by the driver and then fed back to the series regulator in the correct phase and amplitude to counteract the difference. In this manner, the constant voltage comparator helps to maintain a constant output voltage and also generates the error signal necessary to set the output voltage at the level established by the VOLTAGE controls.

4-4 During constant current operation, the constant current comparator detects any difference between the voltage drop developed by the load current flowing through the current sampling resistor and the voltage across the CURRENT control. If the two inputs to the comparator are momentarily unequal, an error signal is generated which (after amplification) alters the conduction of the series regulator by the amount necessary to reduce the error voltage at the comparator input to zero. Hence, the IR drop across the current sampling resistor, and therefore the output current, is maintained at a constant value.

4-5 The constant voltage comparator, then, tends to achieve zero output impedance by altering the output current whenever the load resistance changes. Conversely, the constant current comparator attempts to achieve infinite output impedance by changing the output voltage in response to any load resistance changes. Thus, it is obvious that the two comparison amplifiers cannot operate simultaneously. When the supply is operated within the two normal ranges of output voltage/current, it must act either as a constant voltage source or as a constant current source - it cannot be both. Further, as previously mentioned, if the supply is set to operate outside of the specified high voltage range current rating (i.e. both VOLTAGE and CURRENT are set to high values), the supply will enter the current mode and limit output current if the load resistance attempts to draw more than one-half of the maximum current rating of the supply. As it limits output current, the supply also lowers output voltage (overriding the VOLTAGE setting) until the low voltage range is reached. At this point, the supply enters the constant current mode in which the output current is maintained (up to the maximum rating of the supply) at the CURRENT setting by altering the output voltage.

4-6 Figure 4-2 shows the output characteristics of a constant voltage/constant current power supply. When operated within either of the two normal output voltage/current ranges (0-40V up to 1A or 0-20V up to 2A for the 6104A/6114A supplies or 0-100V up to .4A or 0-50V up to .8A for the 6105A/6115A supplies). With no load attached

($R_L = \infty$), $I_{OUT} = 0$, and $E_{OUT} = E_S$, the front panel voltage control setting. When a load resistance is applied to the output terminals of the power supply, the output current increases, while the output voltage remains constant; point D thus represents a typical constant voltage operating point. Further decreases in load resistance are accompanied by further increases in I_{OUT} with no change in the output voltage until the output current reaches I_S , a value equal to the front panel current control setting. At this point the supply automatically changes its mode of operation and becomes a constant current source; still further decreases in the value of load resistance are accompanied by a drop in the supply output voltage with no accompanying change in the output current value. With a short circuit across the output load terminals, $I_{OUT} = I_S$ and $E_{OUT} = 0$.

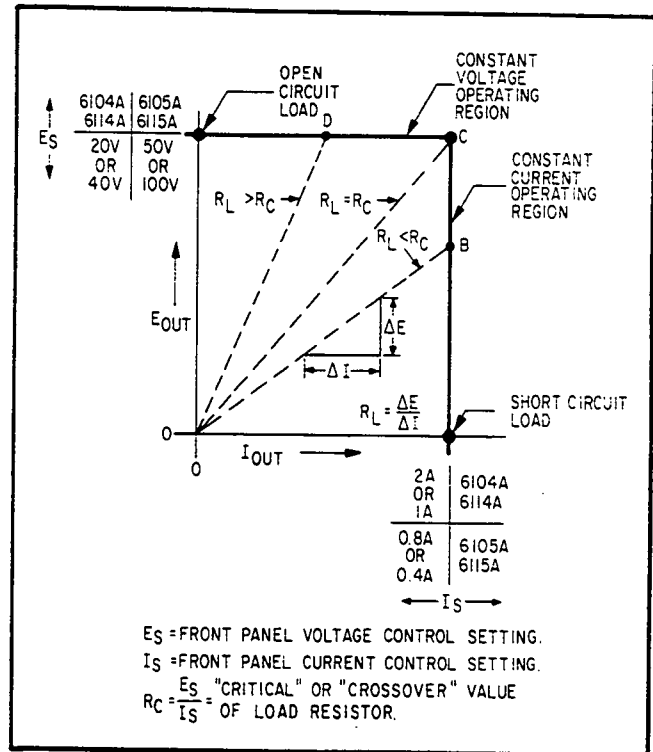

Figure 4-2. Operating Locus of a CV/CC Supply Operated Within Range Ratings

4-7 Thus, at VOLTAGE and CURRENT settings within the two normal ranges, the "crossover" value of load resistance can be defined as $R_C = E_S / I_S$. Adjustment of the front panel VOLTAGE and CURRENT controls permits this "crossover" resistance R_C to be set to any desired value from 0 to ∞ . If R_L is greater than R_C , the supply is in constant voltage operation, while if R_L is less than R_C , the supply is in constant current operation.

4-8 Figure 4-3 shows the output characteristics of the supply when it is operated at an output current setting above the high voltage range rating

(assume the CURRENT control, I_S , and VOLTAGE control, E_S , are set at the maximum rating of the supply). As can be seen, up to the maximum high voltage range current rating, the supply operates as a constant voltage source furnishing the high range output voltage as specified by the setting of the VOLTAGE control. As load resistance decreases and output current reaches the maximum high voltage range current rating (point A), the supply goes into the gross current limit region in which the output current is maintained up to approximately 130% (at nominal line voltage) of the high voltage range current rating. If the load resistance continues to decrease and attempts to draw more current, the output current will increase slightly while the output voltage decreases rapidly (since the gross current limit circuit supplies a near constant current output, a decrease in load resistance results in a decrease in output voltage). When the output voltage reaches a point approximately 130% (again, at nominal line) of the low voltage range rating (point B), the gross current limit circuit turns off and the output current increases up to the programmed value. At this point, the supply enters the constant current mode in which, as described above, the output voltage is varied to maintain the output current at the setting of the CURRENT control. Notice, then, that under these circumstances the VOLTAGE control of the supply is overridden by the gross current limit circuit and the supply is automatically switched to the low voltage range. Since the gross current limit circuit is not as precise as the constant voltage and current comparators, the maximum voltage and current outputs of the supply dur-

ing gross current limit is slightly above the maximum ratings of the supply thus allowing for a margin of safety in that the supply will provide up to approximately 130% of high voltage range current rating and, conversely, it will supply 130% of low voltage range voltage while supplying maximum current (if operated in this region, however, power supply specifications such as output ripple are adversely affected).

4-9 The reference supply provides stable reference voltages used by the constant voltage comparator, the constant current comparator, and the driver. In addition, unregulated +28V is supplied to front panel indicator circuits. Less critical operating voltages are provided by the bias supply.

4-10 The overvoltage protection crowbar monitors the output of the supply, and if it exceeds a preset (adjustable) threshold, fires an SCR which applies a virtual short circuit across the supply, thus reducing the output voltage to approximately zero.

4-11 The meter circuit provides a continuous indication of the output voltage and/or current of the supply (two meters are provided in the 6104A and 6105A models). Output voltage is sensed directly across the sensing terminals, while output current is sensed by monitoring the IR drop across the current sampling resistor.

4-12 DETAILED CIRCUIT ANALYSIS

4-13 GENERAL

4-14 Except for differences due to the different voltage/current ratings of the power supplies and the different VOLTAGE controls and meter circuits employed, all of the supplies operate in a similar fashion. Since the supplies are similar, two schematics have been provided, one for the dual-meter, ten-turn VOLTAGE control supplies (the 6104A and 6105A) and one for the single meter, pushbutton VOLTAGE control supplies (the 6114A and 6115A). Generally, then, the following discussions apply to the 6104A, 6114A, 6105A, or 6115A supplies. For clarity, however, certain circuits (i.e., the series regulator) are discussed for specific supplies (the 6104A/6114A). Except for the different voltage and current values, these discussions apply equally to the other supplies. Further, where specific differences in circuit operation exist between power supply models, they are discussed for each supply.

4-15 VOLTAGE FEEDBACK LOOP

4-16 The voltage feedback loop functions to maintain the output voltage of the supply constant. For purposes of this discussion, assume that the output voltage instantaneously rises (goes positive) due to a change in the external load circuit. The

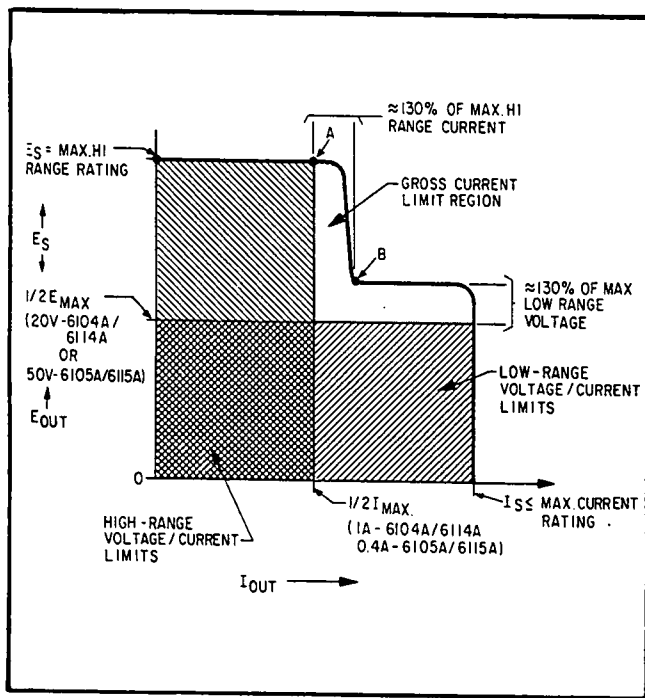

Figure 4-3. Operating Locus of Supply When Operated Out of Voltage/Current Range Limits

change may be in the form of a slow rise in the output voltage or a positive-going ac signal. The slow voltage change is coupled to summing point A1 through the VOLTAGE control (either the ten-turn potentiometer for Models 6104A and 6105A or the pushbutton assembly for Models 6114A and 6115A). The ac signal is coupled to A1 through capacitor C1.

4-17 The rise in output voltage causes the voltage at terminal A1 and thus pin 3 of the constant voltage comparator to decrease (the +S potential rises, goes positive, so that -S is more negative with respect to +S; therefore, the input to the voltage comparator goes negative). This input (pin 3) of the constant voltage comparator is the non-inverting input so that the comparator's output voltage also decreases. This negative-going error voltage is coupled through OR-gate diode A2CR2, amplified by pre-driver A1Q1, and then fed to the series regulator via driver Q4 (located on the rear heat sink). The negative-going input to the series regulator causes the series transistors to decrease their conduction so that they drop more of the raw dc input voltage, thus reducing the output voltage to the original pre-disturbance level.

4-18 CURRENT FEEDBACK LOOP

4-19 When operated within either of the two specified range ratings, if the external load resistance decreases below the "crossover" point discussed in paragraph 4-7, the supply will operate in the constant current mode. In this mode, the feedback loop functions to maintain the output current at a constant level. For purposes of this discussion, assume that the output current instantaneously rises (goes positive) due to a change in the external load circuit. This current change causes the voltage across the current sampling resistor to rise; this change is coupled through front panel CURRENT control R2 to summing point A5 and thus to pin 3 of the constant current comparator as a decreasing (less positive) input. The output of the comparator, then, decreases. This negative-going error voltage is coupled through OR-gate diode A2CR3 to pre-driver A1Q1. At this point the voltage and current feedback loops are joined. As discussed in paragraph 4-17, the negative-going error voltage is amplified in pre-driver A1Q1, and fed through driver Q4 (mounted on the heat sink) to the series regulator. The series regulator thus decreases its conduction and returns the output current to the original pre-disturbance level by decreasing output voltage.

4-20 CONSTANT VOLTAGE COMPARATOR

4-21 The constant voltage comparator consists of the VOLTAGE programming resistors (R4 for models 6104A/6105A and A3R1-A3R17 for models 6114A/

6115A) and a differential amplifier stage (A2U2 and associated components). An integrated circuit is used for the differential amplifier in order to minimize differential voltages due to mismatched transistors and thermal differentials.

4-22 The constant voltage comparator continuously compares the voltage drop across the VOLTAGE control with the output voltage and, if a difference exists, produces an error voltage whose amplitude is proportional to this difference. The error signal ultimately alters the conduction of the series regulator which, in turn, alters the output current so that the output voltage becomes equal to the voltage drop across the VOLTAGE control. Hence, through feedback action, the difference between the two inputs to A2U2 is held at zero volts.

4-23 One input of the differential amplifier (pin 2) is connected to the output voltage sensing terminal of the supply (+S) through matching resistor R16. Potentiometer R13 provides a variable input bias that allows the output voltage of the supply to be adjusted to exactly zero when the supply is programmed for zero output. The other input of the differential amplifier (pin 3) is connected to a summing point (TB1-A1) at the junction of the programming resistors and the current pullout resistor A2R24. Instantaneous changes in the output voltage at the summing point due to manipulation of the VOLTAGE control or changes in the external load circuit produce a difference voltage between the two inputs of the differential amplifier. This difference voltage is amplified and appears at the output of the differential amplifier (pin 6) as an error voltage which ultimately varies the conduction of the series regulator.

4-24 Resistor R15, in series with the summing-point input to the differential amplifier, limits the current through the programming resistors during rapid voltage turn-down. Diodes CR5 and CR6 prevent excessive voltage excursions from over driving the differential amplifier. Notice that when the power supply is in the constant current mode, the output of the voltage differential amplifier (A2U2) approximately +15.5V (with respect to $\boxed{+S}$) and turns on transistor A2Q3 thereby turning on the front panel CURRENT MODE indicator DS2 (a light-emitting diode). Triple junction diode CR7 provides sufficient voltage drop to keep Q3 cutoff when the supply is in constant voltage mode.

4-25 During constant voltage operation, the programming current flowing through the programming resistor(s) (VOLTAGE control) is held constant because of selectable resistor A2R3 and potentiometer A2R5 which allow the +16V reference to be calibrated. The reference voltage is dropped across high-tolerance (.05%) current pullout resistor A2R24

thereby assuring a constant current flow through the VOLTAGE programming resistors. See Section V for procedures to be used in calibrating this reference and thereby assuring linear voltage programming capability.

4-26 Main output capacitor A1C12 stabilizes the series regulator feedback loop when the normal strapping pattern shown on the schematic is employed. Note that this capacitor can be removed (by unstrapping terminal A8) to avoid output current surges or to increase the programming speed of the supply. An additional output capacitor (C1), connected across the front output terminals, helps maintain a low ac output impedance by compensating for the inductive reactance of the main output capacitor at high frequencies. C1 also prevents any spikes in the output from reaching the load.

4-27 CONSTANT CURRENT COMPARATOR

4-28 While basically similar in operation to the constant voltage comparator, the constant current comparator includes a current programming constant current source circuit not employed in the constant voltage comparator. This circuit provides a constant current for the CURRENT programming control and is not utilized in the constant voltage comparator because the voltage comparator must respond to variations in programming voltage (current) when remote voltage sensing is employed (the variations may be caused by the remote sensing leads). As in the constant voltage comparator, the constant current comparator employs an integrated circuit (A2U3) for the differential amplifier in order to minimize differential voltages due to mismatched transistors and thermal differentials.

4-29 The constant current comparator circuit continuously compares the voltage drop across the CURRENT control with the voltage drop across the current sampling resistor, A1R15. If a difference exists, the differential amplifier produces an error signal which is proportional to this difference. The remaining components in the feedback loop (driver and series regulator) function to maintain the drop across the current sampling resistor, and hence the output current, at a constant value.

4-30 One input (pin 2) of the differential amplifier is connected to the inboard side of current sampling resistor A1R15 through matching resistors A2R11 and A1R18. Potentiometer A2R12 provides a variable input bias that allows the output of the supply to be adjusted to zero current when the supply is set for zero output. The other input to the differential amplifier (pin 3) is connected to the summing point (terminal A5) at the junction of the current programming resistor (A1R2) and current programming constant current source (A2Q4 and A2Q5).

Changes in the output current due to load changes or changes in the voltage at the summing point due to manipulation of the CURRENT control produce a difference voltage between the two inputs of the differential amplifier. This difference voltage is amplified and appears at the output of the differential amplifier (pin 6) as an error voltage which varies the conduction of the series regulator (assuming the supply is in constant current operation in which case the output of the constant voltage comparator is approximately +15.5V which reverse biases OR gate diode A2CR2).

4-31 The programming current constant current source (Q4 and Q5 and associated components) provides a constant current for the CURRENT programming control. Zener diode A2VR2 is a constant current source and places the emitter of Q4 at a fixed +9.8V. With the collector and base of Q4 strapped together, the transistor acts as a diode and drops .7V so that the base of Q5 is held at a positive voltage and the transistor is forward biased, supplying a fixed, constant current to the programming control. Potentiometer A2R19 allows the constant programming current to be precisely set at the full output current rating of the supply (see Section V, for calibration procedures).

4-32 DRIVER CIRCUIT

4-33 The driver amplifies the error signal from the constant voltage or constant current input circuit to a level sufficient to drive the series regulating transistors. Transistor A1Q1 receives the error voltage input from either the constant voltage or constant current comparator via the OR-gate diode (A2CR2 or A2CR3) that is conducting at the time. Diode CR2 is forward biased and CR3 is reverse biased during constant voltage operation. The reverse is true during constant current operation.

4-34 Pre-driver transistor A1Q1 receives the error signal and applies it to driver transistor Q4. Driver Q4 controls the conduction of the series regulator by controlling the amount of drive current diverted away from the regulator. As Q4 increases its conduction, more drive current (flowing from the +7.5V bias source through R33) is diverted from the bases of Q2 and Q3, causing a decrease in their conduction and a corresponding decrease in the output voltage.

4-35 Driver transistor Q4 performs an additional function, that of discharging the output capacitor during rapid down-programming. When the supply is rapidly down-programmed, diode CR13 conducts; a current path is thus established from the positive of output capacitor A1C12 through Q4 and back to the negative of the capacitor (thru R25). A1R14, in series with CR13 and CR14, limits the current that

can flow through this path. Triple junction diode CR14 protects Q4 from reverse voltages that could be developed across it in situations such as Auto-Series operation when one supply is turned on before the other. In addition, CR14 also maintains the emitter of Q1 and the base of Q4 at a constant potential, thus limiting the power dissipated in Q4 under conditions where an external same-polarity voltage is applied to the output terminals of the supply (such as battery charging/discharging).

4-36 SERIES REGULATOR

4-37 The series regulator consists of transistors Q1 through Q3 (mounted, along with driver Q4, on the heat sink) which serve as the series or "pass" element that, by varying its conductance in accordance with error signals produced by the constant voltage and constant current comparators, provides precise control of the output voltage and current during in-range operation. The regulator utilizes a "power sharing" circuit that results in considerably less internal power dissipation than would be the case if a standard, single-stage regulator were employed. This saving in dissipation is achieved by dividing the output of the supply into two regions (the low and high voltage ranges), and using separate raw-dc supplies for each region (range). Maximum dissipation in any single-stage regulator circuit occurs when the supply is short-circuited at full output current; under this condition, the entire raw-dc voltage must be dropped across the series regulator while it is conducting the full output current. It can be seen, then, that if the raw-dc voltage is made as low as possible when the supply is operating at a low output voltage, the power dissipated in the series regulator will be minimized.

4-38 The series regulator also includes a gross current limit circuit (zener diode 1VR2 and associated resistors R5, R6, and R7) that overrides the error signal produced by the comparators if excessive current is drawn when the output voltage is in the high range. The following paragraphs discuss the operation of the 6104A/6114A series regulator during two modes of operation: (1) when the voltage and current settings are within the normal limits for both two output ranges (and, therefore, the comparators have complete control of the series regulator) and (2) when the voltage setting is at the high range and the current setting is also set at a high value (in which case the gross current limit circuit activates if the high voltage range current rating, half of the low voltage range current rating, is exceeded). The 6105A/6115A series regulator circuit operates in the same way except that voltage levels are higher (and output current less).

4-39 The power supply utilizes dual full-wave rectifier-filters to obtain two raw-dc supply volt-

ages which are represented as two independent sources in Figure 4-4, a simplified schematic of the series regulator circuit. Switching between the sources is accomplished by diodes CR11 and CR12. In order to best understand the action of these diodes, the circuit will be analyzed for two separate, in-range conditions - high and low output voltage after which it will be discussed from the point of view of an out-of-range condition (i. e. the voltage and current controls are both set to high rating). To simplify the discussion, assume that the diode voltage drops and the transistor base-emitter junction voltages are all 1V when forward biased. Similarly, assume that the voltage across zener diodes VR3 and VR4 is 6.5V total.

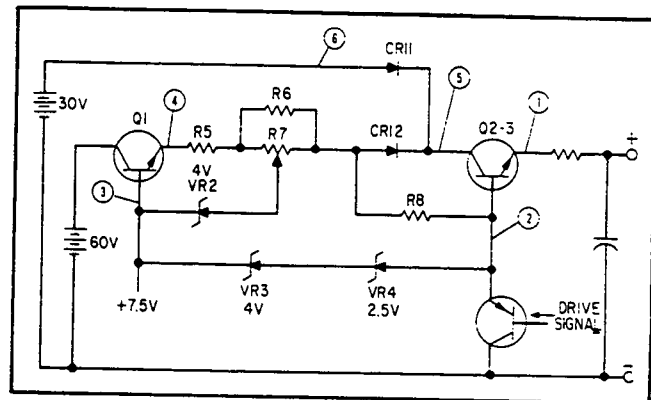

Figure 4-4. Series Regulator, Simplified Schematic (Models 6104A/6114A)

4-40 At a low output voltage (point ① = 5V), transistors Q2 and Q3 are conducting; this requires point ② to be at 6V. Zener diodes VR3 and VR4 thus place the base of Q1 (point ③) at 12.5V. Resistor R8 keeps Q1 conducting at least a certain minimum current at all times; thus point ④ is at 11.5V. Diode CR12 must be either on or off. If it were on, point ⑤ would be at 10.5V. Since the anode of CR11 (point ⑥) is always at 30V, this condition is not possible so that CR12 must be off. Thus, CR11 is on, point ⑤ is at 29V, and the 30V raw-dc source is supplying the load. The power dissipation in Q2 and Q3 is thus approximately 48 watts (24V drop between points ① and ⑤ times 2A load current). Notice that under these conditions, with a minimum current through Q1, the drop across R5 is small and the bias across zener diode VR2 is not sufficient for the zener to conduct current (the zener is not biased past its breakdown voltage) so that the gross current limit circuit has no effect on the operation of the series regulator.

4-41 At a high output voltage (point ① = 40V), transistors Q2 and Q3 are again conducting and point ② is at 41V. Point ③ thus is at 40.5V due to zener diodes VR3 and VR4. Point ④ is at 47.5V because (as before) Q1 is always conducting at least a certain minimum current. Again, diode CR12 must either be on or off. Since point ⑥ is

at 30V, CR12 must be on and CR11 must be off (point ⑤ = 46.5V). Thus, the 60V raw-dc source is supplying the load. Notice, again, that in the high voltage range, up to 1 amp. supplied by the 60V source so that the voltage drop across R5 is still not great enough to bias VR2 past its breakdown point. VR2, then, still has no effect on the operation of the series regulator. The switching point between the two ranges occurs when the voltage at point ④ equals that at point ⑥ (30V); this occurs when the output is approximately 21V (51V for the 6105A and 6115A).

4-42 Figure 4-5 illustrates the in-range operation of the series regulator from a power dissipation point of view. When the output voltage is in the low range (between zero and 21 volts for the 6104A and 6114A or 0-51 volts for the 6105A and 6115A), transistors Q2 and Q3 are controlling the output. In this region, the power dissipation of Q1 is very low (approximately 1W), since the only current going through it is that flowing through R8. When the output voltage is in the high range (between 21 and 40 volts or 51 and 100) most of the regulator dissipation occurs in transistor Q1 with transistors Q2 and Q3 clamped to a low voltage (and dissipating approximately 7.5W).

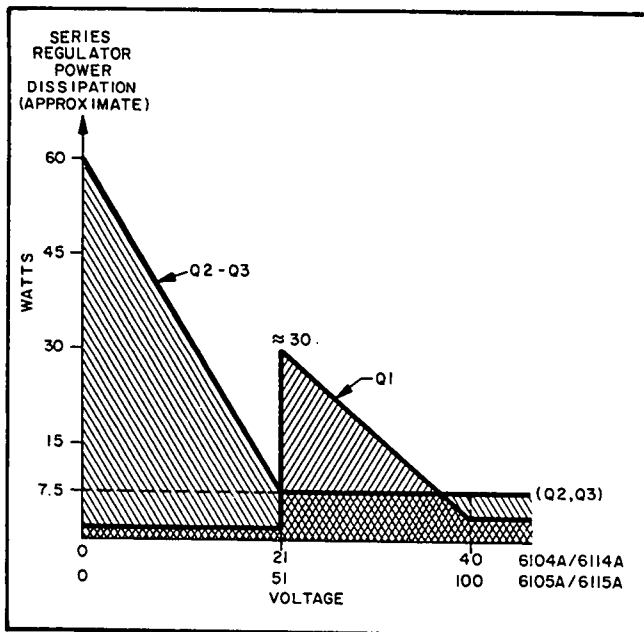

Figure 4-5. Series Regulator Power Dissipation

4-43 The obvious advantage in this type of regulator circuit is the saving in power dissipation. Consider the case discussed in paragraph 4-40, where the supply output is 5 volts at 2 amps, and the regulator is dissipating 48 watts. If the supply used a conventional single-stage regulator, the raw-dc source would have to be approximately 48V (20% higher than the maximum rated output voltage of 40V). The power dissipated by the regulator would therefore be the voltage drop across it (43

volts) times the current conducted (2A), or 86 watts. The use of the power sharing regulator thus represents a power dissipation saving (in this particular case) of more than 170%.

4-44 Referring back to paragraph 4-41, it was noted that since the output current is held (by the constant current comparator) to 1A when the output voltage is in the high range, zener diode VR2 had no effect on circuit operation since the voltage across it does not exceed its breakdown voltage. However, assuming that the CURRENT control is set to 2A and the VOLTAGE control is still set at 40V, if the load resistance decreases and attempts to draw more than approximately 1A through Q1 (and R5), the reverse voltage across VR2 exceeds the breakdown voltage of the zener diode. At breakdown, the diode becomes a constant current source and limits the current through the regulator to approximately 1.3A (at nominal line voltage). If load resistance decreases further, output voltage is reduced (since the zener is a constant current source) until the crossover point between the raw-dc sources is reached (point ⑤ is at approximately 21V). At this point, CR12 is cut off and CR11 is forward biased and the regulator reverts to the low voltage range of operation described in paragraph 4-40. The supply, then, will output the specified current and operate as a constant current source, responding to the error signal developed by the constant current comparator. The voltage setting, then, is overridden and output voltage will be adjusted between 0 and 20V to maintain the output current at the required value. Resistor R7 allows the gross current limit region to be calibrated (R7 is set at the factory at low line voltage to allow gross current limit at approximately 1.2A for the 6104A and 6114A supplies or at 0.48A for the 6105A and 6115A supplies).

4-45 REFERENCE SUPPLY

4-46 The reference supply includes a feedback regulator, similar to the main supply, that provides stable reference voltages (referenced to $\boxed{+S}$) that are used throughout the unit. The regulated +16V reference voltage is derived from dc obtained from full wave rectifier A1CR1-CR2 and filter capacitor A1C1. In addition, zener diode A1VR3 provides -14.7V reference voltage that is also used throughout the unit. Also, zener diode VR4 (with R26) provides a regulated -6.2V for use in the overvoltage crowbar circuit. The -14.7V and -6.2V are derived from dc obtained from full wave rectifier A1CR3-CR4 and filter capacitor A1C2. The +16V and -14.7V/-6.2V reference rectifiers are returned to common point $\boxed{+S}$. Notice, too, that the raw-dc input to the +16V regulator is 28V (nominal) which is used, unregulated, in the CURRENT MODE indicator and overvoltage crowbar circuits.

4-47 The +16V regulating circuit consists of series regulating transistor A2Q1, driver A2Q2, and comparison amplifier A2U1. As for the constant voltage and constant current comparators, the +16V regulator utilizes an integrated circuit for the comparison amplifier to minimize transistor mismatches and thermal differentials. The voltage across zener diode VR1 and resistor R9 and the voltage at the junction of the voltage divider comprised of resistors R8B, R5, R8A, and R3 (R3 is selected at the factory) are compared and any difference is amplified by the comparison amplifier. The error voltage thus appearing at the output (pin 6) of the comparison amplifier is amplified by driver stage A2Q2 and applied to series regulator Q1 in the correct phase and amplitude to maintain the +16V output at a constant level. Potentiometer R5 is provided to allow the +16V reference to be precisely calibrated (see Section V).

4-48 Resistor R1 and diode CR1 provide an initial turn on current path for the base-emitter circuit of series regulator Q1. This current flow initiates the series regulator action by turning on Q1. In addition, diode CR1 assures the correct operation of the comparison amplifier by establishing the positive bias of the amplifier at a level that is always above (by an amount equal to the drop across CR1) the output of the comparison amplifier. Capacitor A2C2, connected across the output of the reference supply, removes spikes and stabilizes the reference regulator loop.

4-49 BIAS SUPPLY

4-50 Additional +7.5V, +3V, and -4.3V bias voltages are derived from dc obtained from full wave rectifier A1CR5-CR6 and filter capacitor A1C3 along with dropping resistor A1R3. Capacitor A1C10 removes spikes from the bias supply output voltages. The +7.5V bias output is developed across zener diodes A2VR3 and VR4 in the series regulator. Zener diode VR4, in conjunction with the drop across series regulator transistors Q2 and Q3, develops the +3V bias voltage. The -4.3V bias voltage is supplied by zener diode A2VR5. Resistor R40, connected across VR5 limits the maximum current through the diode and also reduces overshoot when the supply is turned on or off.

4-51 OVERVOLTAGE PROTECTION CROWBAR

4-52 The overvoltage protection crowbar circuit protects the load from high voltage conditions such as might result from the failure of the series regulator transistors. This protection is accomplished by placing a short across the output of the supply thus driving output voltage and current towards 0. The overvoltage protection crowbar circuit utilizes an integrated circuit (A1U1) comparison amplifier

that provides high gain and high speed with low temperature coefficient and power consumption. Under normal operating conditions (no overvoltage), the output of the comparison amplifier is positive and capacitor C14 is charged positive. No trigger signal, therefore, is received by silicon controlled rectifier (SCR) CR20 and it is an open circuit having no effect on the normal output voltage.

4-53 Potentiometer R3 (OVERVOLTAGE) has -6.2V (with respect to +S) applied across it from the reference supply. The other input to the comparison amplifier is taken at the junction of voltage divider R29 and R30 which is across the output terminals of the supply and divides the output voltage to a maximum of approximately -6.2V when the supply is set to maximum rated output. When the voltage input to pin 3 of the comparison amplifier exceeds (is less negative) the voltage at pin 2, the output of the amplifier goes negative (approximately 0) and capacitor C14 discharges through the primary of transformer T1. A positive trigger pulse, then, is applied to the gate lead of CR20 and the SCR is turned on, placing a virtual short across the output of the supply. Potentiometer R3, adjusts the point at which the crowbar will trip by increasing (or decreasing) the negative reference input to the comparison amplifier and, thereby, requiring the output voltage to increase (or decrease) in a negative direction before it is more negative than the reference input (to cause the amplifier output to go towards 0).

4-54 When triggered, the SCR has two paths through which it conducts current as follows. Assuming the series regulator transistors (Q2 and Q3) are not open, diode CR16 is forward biased when the SCR fires and the output current flows from the + output terminal, the base-emitter junctions of Q2-Q3, the +7.5V supply, this diode, and through the SCR. Thus, current is diverted from the series regulator transistors and the output current (and of course, voltage) is turned down rapidly. The current surge through the SCR, therefore, is minimized. The other current path for the SCR is via diode CR17 and the output terminals. However, if the series regulator transistors are operable, most current flows through the CR16 path. In the case when the series regulator transistors collector-emitter junction shorts (which would open the CR16 current path described above), the SCR will conduct all the current through this path (the current surge will, however, be sustained for a longer time until the supply fuse opens). Diode CR17 assures that the CR16 path is not turned on during normal operation when output voltage is set below +7.5V.

4-55 Resistor R27 limits the current flowing into the gate of the SCR and diode CR18 prevents ringing in the pulse transformer when the positive

trigger pulse collapses. Resistor R34 limits the current flowing through the SCR and inductor L1 is included to decrease the response time of the SCR and minimize false triggering (triggering of the SCR due to noise spikes). Note, also, that when the crowbar fires, diode CR16 is forward biased (as mentioned previously) which forward biases front panel OVERVOLTAGE indicator DS3 which is a light-emitting diode.

4-56 A slaving arrangement of crowbar circuits in more than one unit is made possible by an extra secondary winding (terminals 7 and 8) on transformer T1. Terminals on the rear barrier strip (A13 and A14) allow easy connection to this winding. Connecting these windings in parallel when operating in a multiple-supply configuration will result in all the crowbars being activated if one of the crowbars is tripped. To reset the crowbars in this arrangement, all of the units must be turned off and then on. Correct polarity (A13 is positive) must be observed when connecting the windings in parallel. Figures 3-10 through 3-12 (Parallel, Auto-Parallel, and Auto-Series) demonstrate these connections. Also, the crowbars can be interconnected down to a load impedance of approximately 10Ω (each crowbar pulse winding has approximately 100Ω impedance) after which considerable degradation of the pulse may occur.

4-57 METER CIRCUIT

4-58 The meter circuit provides continuous indication of the output voltage and/or output current. Individual voltage and current meters are supplied in the 6104A and 6105A supplies while a single meter that can be used either as an ammeter or a voltmeter, depending on the position of the front panel METER switch S2, is provided in the 6114A and 6115A supplies. The following paragraphs describe each of the two meter circuits.

4-59 Dual-Meter Circuit (6104A and 6105A). To measure voltage, the voltmeter and its series resistors, A1R20 and A1R22, are connected between the positive and negative sensing terminals. Potentiometer A1R22 allows the voltmeter to be calibrated. For current measurements, the ammeter is connected across the current sampling resistor. Potentiometer A1R17 allows the ammeter to be calibrated. Notice that during constant current operation, the voltmeter and its resistors act as a shunt load across the output terminals of the supply, drawing a small amount of current away from the load (0-1mA, depending on the output voltage). Voltage divider A1R18 and A1R21 compensates for this decrease in load current by subtracting a small voltage (the drop across R18) from the voltage drop across the current sampling resistor. The sub-

tracted voltage causes the constant current comparator to increase output current just enough to balance the current supplied to the meter circuit.

4-60 Single Meter Circuit (6114A and 6115A). The voltage and current measuring circuits for the 6114A and 6115A are selected by front slide switch S2 and are similar to the associated dual meter circuit previously discussed. For voltage measurements, the meter and series resistors A1R17, A1R22, and A1R20 are connected across the positive and negative sensing terminals with A1R22 used to calibrate the meter. Notice, also, that when slide-switch S2 is in the VOLTS position, resistors A1R16 and A1R19 are connected across the current sampling resistor in order to "replace" the current measuring circuit that is connected across the current sampling resistor when the switch is in the AMPS position. Thus, the effect of the meter circuit on the constant current performance of the supply will be the same regardless of the position of the meter switch. Similarly, when measuring current (S2 in AMPS position), the meter and series resistors A1R16 and A1R17 are connected across the current sampling resistor with A1R17 used to calibrate the meter. Further, resistors A1R19 and A1R20, and A1R22 are connected across the positive output terminal and the negative sensing terminal to "replace" the voltage measuring circuit. As described for the dual-meter circuit, the small voltage drop across resistor R18 compensates for the shunt load of the meter circuit which might (because it drains up to 1mA) affect constant current operation. This voltage drop causes the constant current comparator to increase output current just enough to balance the current supplied to the meter circuit.

4-61 ADDITIONAL PROTECTION FEATURES

4-62 The supply contains several "special purpose" components which protect it in the event of unusual circumstances. One of these components is diode A1CR15. Connected across the output terminals of the supply, the diode prevents internal damage from reverse voltages that might be applied across the supply. This could occur, for example, during Auto-Series operation if one supply was turned on before the other.

4-63 Diodes CR23 and CR24 limit the output of the supply if the connections between both output terminals and the sensing terminals ($\pm S$) are inadvertently removed. Diode CR14, previously mentioned in the driver amplifier description, protects the driver stage from damage due to same-polarity voltages that might be applied to the supply in such applications as battery charging and discharging.

SECTION V MAINTENANCE

5-1 INTRODUCTION

5-2 Upon receipt of the power supply, the performance check (Paragraph 5-5) should be made. This check is suitable for incoming inspection. If a fault is detected in the power supply while making the performance check or during normal operation, proceed to the troubleshooting procedures (Paragraph 5-53). After repair and replacement (Paragraph 5-70), perform any necessary adjustments and calibrations (Paragraph 5-83). Before returning the power supply to normal operation,

repeat the performance check to ensure that the fault has been properly corrected and that no other faults exist. Before performing any maintenance checks, turn on the power supply and allow a half-hour warm-up.

5-3 TEST EQUIPMENT REQUIRED

5-4 Table 5-1 lists the test equipment required to perform the various procedures described in this section.

Table 5-1. Test Equipment Required

| TYPE | REQUIRED CHARACTERISTICS | USE | RECOMMENDED MODEL |
|------------------------|-----------------------------------------------------------------------------------------------------------------------------------------|-----------------------------------------------------------------------------|-----------------------------------------------------------------------------------------------------------------------------------------|
| Differential Voltmeter | Sensitivity: 500 μ V full scale (min.). Input impedance: 100M Ω (min.). | Measure dc voltages; calibration procedures. | HP 3420B (See Note on Page 5-2.) |
| Oscilloscope | Sensitivity and bandwidth: 50 μ V/cm and 300kHz for all measurements except noise spike; 1mV and 20MHz for noise spike measurement. | Measure ripple; display transient recovery waveforms; measure noise spikes. | HP 140A with 1403A vertical plug-in and 1423A time base; HP 180A with 1803A vertical plug-in and 1820A time base for spike measurement. |
| DC Voltmeter | Sensitivity: 1mV full scale (min.). Accuracy: 1%. | Measure dc voltages. | HP 412A. |
| AC Voltmeter | Sensitivity: 50 μ V full scale (min.). Frequency range: 5Hz to 250kHz (min.). Accuracy: 3%. | Measure output impedance, ripple, and ac voltages. | HP 3410A. |
| Oscillator | Frequency range: 5Hz to 20kHz (min.). Output: 5V rms into 600 Ω . Accuracy: 3%. | Measure output impedance. | HP 209A. |
| Amplifier | Power output: 50 watts. Frequency response: \pm 3dB 5Hz to 20kHz (min.). | Measure output impedance. | HP 6824A. |

Table 5-1. Test Equipment Required (Continued)

| TYPE | REQUIRED CHARACTERISTICS | USE | RECOMMENDED MODELS |
|------------------------------|-----------------------------------------------------------------------------------------------------------|--------------------------------------------------------|------------------------------------------|
| Variable Voltage Transformer | Range: 103 to 127Vac. Recommended minimum output current: 5.5A. | Vary ac input for line regulation measurement. | ----- |
| Repetitive Load Switch | Switching rate: 60 to 400Hz. Rise time: 2 μ sec. | Measure transient recovery time. | See Figure 5-6. |
| Variable Resistive Loads | 6104A/6114A: 10 Ω to 40 Ω , 40 watt. 6105A/6115A: 62 Ω to 250 Ω , 40 watt. | Power supply load resistors. | ----- |
| Current Sampling Resistors | Value .1 Ω \pm .1%, 2W | Measure output current; calibrate ammeter. | HP Part No. 0811-2061 |
| Terminating Resistors | Value: 50 ohms, 1/2 watt, \pm 5%, non-inductive, 4 required. | Noise spike measurement. | ----- |
| Blocking Capacitors | Values: 0.01 μ F, 100Vdc, 2 required; 1000 μ F, 60Vdc, 1 required. | Noise spike measurement; output impedance measurement. | ----- |
| Programming Resistor | 1K Ω , 5 watts, \pm .0015% | Calibrating voltage and current programming. | Julie Research Primary Standard NB103 1K |

NOTE

A satisfactory substitute for a differential voltmeter is a reference voltage source and null detector arranged as shown in Figure 5-1. The reference voltage source is adjusted so that the voltage difference between the supply being measured and the reference voltage will have the required resolution for the measurement being made. The voltage difference will be a function of the null detector that is used. Examples of satisfactory null detectors are: HP 419A null detector, a dc coupled oscilloscope utilizing differential input, or a 10 mV meter movement with a 100 division scale. For the latter, a 0.5mV change in voltage will result in a meter deflection of five divisions. For calibration purposes, make sure that null meter has 100 M Ω input impedance.

CAUTION

Care must be exercised to avoid ground loops and circulating currents when using an electronic null detector in which one input terminal is grounded.

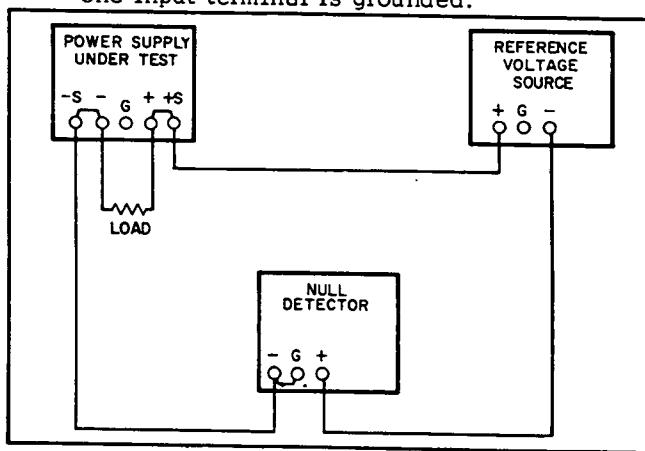

Figure 5-1. Differential Voltmeter Substitute Test Setup

5-5 PERFORMANCE TEST

5-6 The following test can be used as an incoming inspection check and appropriate portions of the test can be repeated either to check the operation of the instrument after repairs or for periodic maintenance tests. The tests are performed using a 115V ac, 60Hz, single phase input power source.

5-7 CONSTANT VOLTAGE TESTS

5-8 All measuring devices must be connected to the rear sensing terminals of the supply and not to the front output terminals if maximum accuracy is to be obtained in the following measurements. In addition, the measuring devices must be connected as close to the sensing terminals as possible. This is particularly important when measuring the transient response, regulation, or ripple of the power supply. Note that under no circumstances should the measuring instruments be connected across the load. A measurement made across the load includes the impedance of the leads to the load and such lead lengths can easily have an impedance several orders of magnitude greater than the supply impedance, thus invalidating the measurement.

5-9 To avoid mutual coupling effects, each monitoring device must be connected to the sensing terminals by a separate pair of leads. Twisted pairs or shielded two-wire cables should be used to avoid pickup on the measuring leads. The load resistor should be connected across the output terminals as close to the supply as possible. When measuring the constant voltage performance specifications, the current controls should be set well above (at least 10%) the maximum output current which the supply will draw, since the onset of constant current action will cause a drop in output voltage, increased ripple, and other performance changes not properly ascribed to the constant voltage operation of the supply.

5-10 Voltage Output Accuracy (6114A and 6115A only).

Definition: Output voltage accuracy at $23 \pm 3^\circ\text{C}$ and any line voltage and load current within rating following 5 minutes warm-up.

To check the accuracy of the output voltage for the 6114A and 6115A (pushbutton control) supplies, proceed as follows:

- Connect load resistor (R_L) indicated in Figure 5-2 (maximum voltage, 1/2 maximum current) across output terminals of supply.
- Connect differential voltmeter across +S and -S terminals of supply, observing correct polarity.
- Turn CURRENT control fully clockwise.
- Turn on supply and allow a five-minute warm-up period.

e. Program output voltage to maximum rating of supply.

f. Differential voltmeter should indicate as follows:

6114A - $40V \pm 11mV$
6115A - $100V \pm 26mV$

5-11 Voltmeter Accuracy. To check the accuracy of the voltmeter, proceed as follows:

a. Connect load resistor (R_L) indicated in Figure 5-2 (maximum voltage, 1/2 maximum current) across output terminals of supply.

b. Connect differential voltmeter across +S and -S terminals of supply, observing correct polarity.

c. Turn CURRENT control fully clockwise.

d. Turn on supply and adjust VOLTAGE controls until differential voltmeter indicates exactly maximum rated output voltage.

e. Front panel voltmeter should indicate the following:

6104A/6114A - $40 \pm .8V$
6105A/6115A - $100 \pm 2V$

5-12 Line Regulation.

Definition: The change ΔE_{OUT} in the static value of dc output voltage resulting from a change in ac input voltage over the specified range from low line (usually 103.5 volts) to high line (usually 126.5 volts), or from high line to low line.

NOTE

The CURRENT MODE light should be off during this test.

5-13 To check the line regulation, proceed as follows:

a. Connect test setup shown in Figure 5-2.
b. Connect variable auto transformer between input power source and power supply power input.

c. Adjust variable auto transformer for 103.5 volts ac input.

d. Turn CURRENT control fully clockwise.

e. Turn on supply and adjust VOLTAGE control until front panel meter indicates exactly maximum rated output voltage.

f. Read and record voltage indicated on differential voltmeter.

g. Adjust variable auto transformer for 126.5 volts ac input.

h. Reading on differential voltmeter should not vary from reading recorded in Step (f) by more than:

6104A/6114A - $240\mu V$
6105A/6115A - $600\mu V$

5-14 Load Regulation.

Definition: The change ΔE_{OUT} in the static value of dc output voltage resulting from a change in load resistance from open circuit to a value which yields maximum rated output current (or vice versa).

5-15 Check the constant voltage load regulation at both maximum voltage/half maximum current output and half maximum voltage/maximum current output. Check load regulation for maximum voltage/half maximum current first and then repeat the procedure to check load regulation at half maximum voltage/maximum current.

NOTE

The CURRENT MODE light should be off during this test.

- a. Connect test set up shown in Figure 5-2; select R_L as applicable for the voltage/current range being checked.
- b. Turn CURRENT control fully clockwise.
- c. Turn on supply and adjust VOLTAGE control until front panel meter indicates exactly half maximum or maximum rated output current as applicable.
- d. Read and record voltage indicated on differential voltmeters.
- e. Disconnect load resistor.
- f. Reading on differential voltmeter should not vary from reading recorded in Step (d) by more than the following:
 1. Maximum Voltage/Half Current:
6104A/6114A - 300 μ V
6105A/6115A - 550 μ V
 2. Half Voltage/Maximum Current:
6104A/6114A - 200 μ V
6105A/6115A - 300 μ V

5-16 Ripple and Noise.

Definition: The residual AC voltage which is superimposed on the DC output of a regulated power supply. Ripple and noise may be specified and measured in terms of its RMS or (preferably) peak-to-peak value.

Ripple and noise measurement can be made at any input AC line voltage combined with any DC output voltage and load current within rating.

5-17 The amount of ripple and noise that is present on the power supply output is measured either in terms of the RMS or (preferably) peak-to-peak value. The peak-to-peak measurement is particularly important for applications where noise spikes

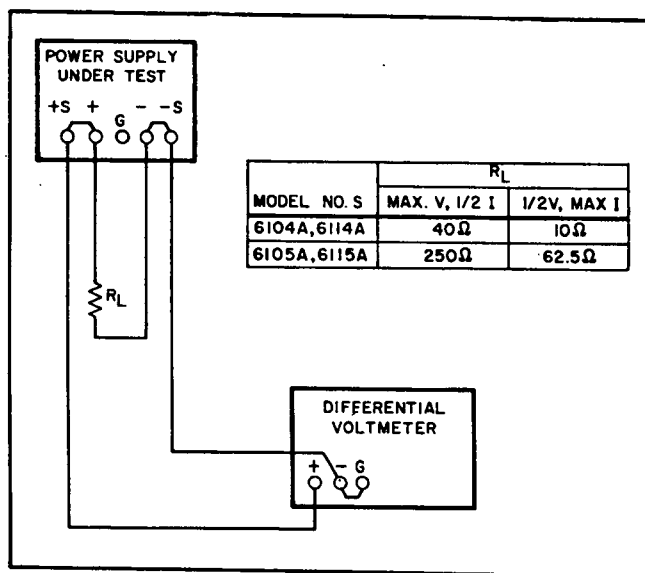

Figure 5-2. Constant Voltage Load Regulation Test Setup

could be detrimental to a sensitive load, such as logic circuitry. The RMS measurement is not an ideal representation of the noise, since fairly high output noise spikes of short duration could be present in the ripple and not appreciably increase the RMS value.

5-18 The technique used to measure high frequency noise or "spikes" on the output of a power supply is more critical than the low frequency ripple and noise measurement technique; therefore the former is discussed separately in Paragraph 5-26.

5-19 Ripple and Noise Measurements. Figure 5-3A shows an incorrect method of measuring p-p ripple. Note that a continuous ground loop exists from the third wire of the input power cord of the supply to the third wire of the input power cord of the oscilloscope via the grounded power supply case, the wire between the negative output terminal of the power supply and the vertical input of the scope, and the grounded scope case. Any ground current circulating in this loop as a result of the difference in potential E_G between the two ground points causes an IR drop which is in series with the scope input. This IR drop, normally having a 60Hz line frequency fundamental, plus any pickup on the unshielded leads interconnecting the power supply and scope, appears on the face of the CRT. The magnitude of this resulting noise signal can easily be much greater than the true ripple developed between the plus and minus output terminals of the power supply, and can completely invalidate the measurement.

5-20 The same ground current and pickup problems can exist if an RMS voltmeter is substituted in place of the oscilloscope in Figure 5-3. However, the oscilloscope display, unlike the true RMS meter

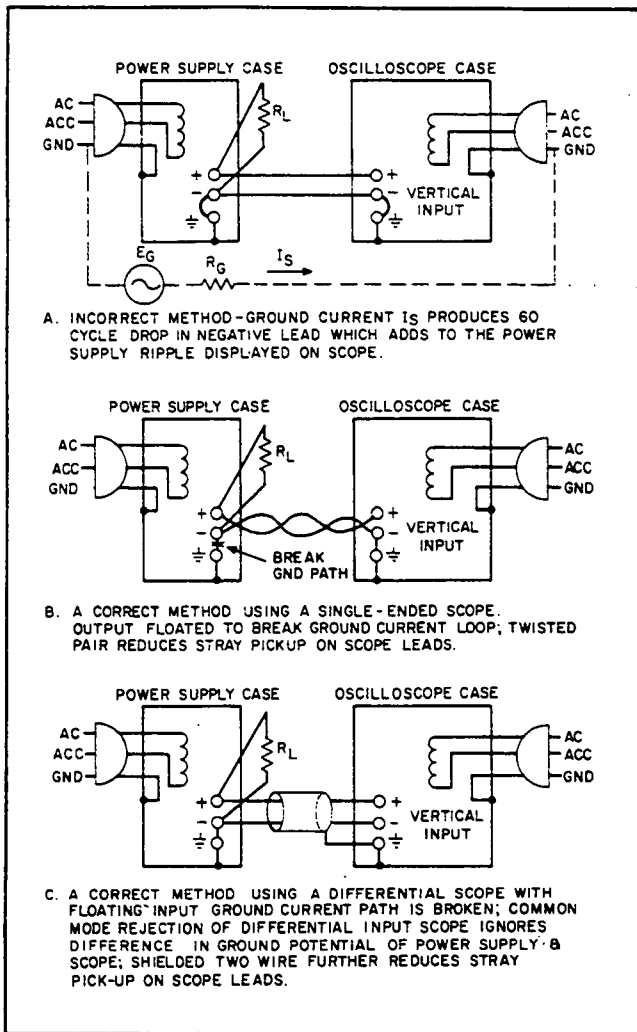

Figure 5-3. Ripple and Noise, Test Setup

reading, tells the observer immediately whether the fundamental period of the signal displayed is 8.3 milliseconds ($1/120\text{Hz}$) or 16.7 milliseconds ($1/60\text{Hz}$). Since the fundamental ripple frequency present on the output of an AC supply is 120Hz (due to full-wave rectification), an oscilloscope display showing a 120Hz fundamental component is indicative of a "clean" measurement setup, while the presence of a 60Hz fundamental usually means that an improved setup will result in a more accurate (and lower) value of measured ripple.

5-21 Figure 5-3B shows a correct method of measuring the output ripple of a constant voltage power supply using a single-ended scope. The ground loop path is broken by floating the power supply. Note that to ensure that no potential difference exists between the supply and the oscilloscope it is recommended that whenever possible they both be plugged into the same ac power buss. If the same buss cannot be used, both ac grounds must be at earth ground potential.

5-22 Either a twisted pair or (preferably) a shielded two-wire cable should be used to connect the output terminals of the power supply to the vertical input terminals of the scope. When using a twisted pair, care must be taken that one of the two wires is connected to the grounded input terminal of the oscilloscope. When using shielded two-wire, it is essential for the shield to be connected to ground at one end only so that no ground current will flow through this shield, thus inducing a noise signal in the shielded leads.

5-23 To verify that the oscilloscope is not displaying ripple that is induced in the leads or picked up from the grounds, the (+) scope lead should be shorted to the (-) scope lead at the power supply terminals. The ripple value obtained when the leads are shorted should be subtracted from the actual ripple measurement.

5-24 In most cases, the single-ended scope method of Figure 5-3B will be adequate to eliminate non-real components of ripple and noise so that a satisfactory measurement may be obtained. However, in more stubborn cases it may be necessary to use a differential scope with floating input as shown in Figure 5-3C. If desired, two single conductor shielded cables may be substituted in place of the shielded two-wire cable with equal success. Because of its common mode rejection, a differential oscilloscope displays only the difference in signal between its two vertical input terminals, thus ignoring the effects of any common mode signal introduced because of the difference in the ac potential between the power supply case and scope case. Before using a differential input scope in this manner, however, it is imperative that the common mode rejection capability of the scope be verified by shorting together its two input leads at the power supply and observing the trace on the CRT. If this trace is a straight line, the scope is properly ignoring any common mode signal present. If this trace is not a straight line, then the scope is not rejecting the ground signal and must be realigned in accordance with the manufacturer's instructions until proper common mode rejection is attained.

5-25 To check the ripple and noise output, proceed as follows:

- Connect the oscilloscope or RMS voltmeter as shown in Figures 5-3B or 5-3C.
- Adjust VOLTAGE control until front panel meter indicates maximum rated output voltage.
- The observed ripple and noise should be less than $40\mu\text{V}$ RMS and $100\mu\text{V}$ p-p.

5-26 Noise Spike Measurement. When a high frequency spike measurement is being made, an instrument of sufficient bandwidth must be used; an

oscilloscope with a bandwidth of 20MHz or more is adequate. Measuring noise with an instrument that has insufficient bandwidth may conceal high frequency spikes detrimental to the load.

5-27 The test setups illustrated in Figures 5-3A and 5-3B are generally not acceptable for measuring spikes; a differential oscilloscope is necessary. Furthermore, the measurement concept of Figure 5-3C must be modified if accurate spike measurement is to be achieved:

a. As shown in Figure 5-4, two coax cables, must be substituted for the shielded two-wire cable.

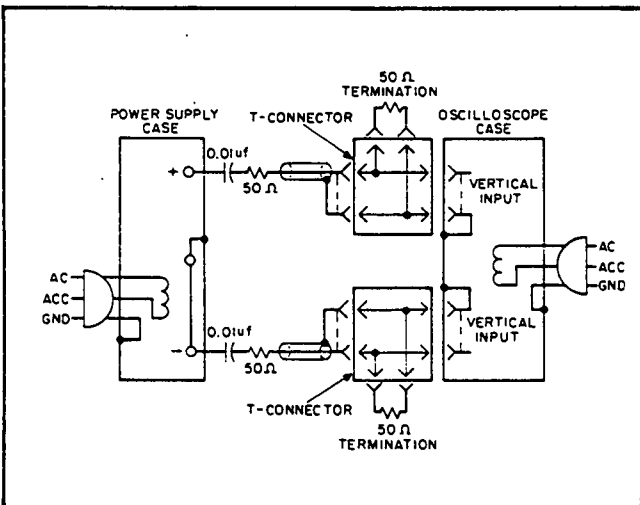

Figure 5-4. CV Noise Spike Test Setup

b. Impedance matching resistors must be included to eliminate standing waves and cable ringing, and the capacitors must be connected to block the DC current path.

c. The length of the test leads outside the coax is critical and must be kept as short as possible; the blocking capacitor and the impedance matching resistor should be connected directly from the inner conductor of the cable to the power supply terminals.

d. Notice that the shields of the power supply end of the two coax cables are not connected to the power supply ground, since such a connection would give rise to a ground current path through the coax shield, resulting in an erroneous measurement.

e. Since the impedance matching resistors constitute a 2-to-1 attenuator, the noise spikes observed on the oscilloscope should be less than 50µV p-p instead of 100µV p-p.

5-28 Transient Recovery Time.

Definition: The time "X" for the output voltage recovery to within "Y" millivolts of the nominal output voltage following a

"Z" amp step change in load current, where: "Y" is specified as 10mV, the nominal output voltage is defined as the dc level halfway between the static output voltage before and after the imposed load change, and "Z" is the specified load current change of the full load current rating of the supply.

5-29 Transient recovery time may be measured at any input line voltage combined with any output voltage and load current within rating.

5-30 Reasonable care must be taken in switching the load resistance on and off. A hand-operated switch in series with the load is not adequate, since the resulting one-shot displays are difficult to observe on most oscilloscopes, and the arc energy occurring during switching action completely masks the display with a noise burst. Transistor load switching devices are expensive if reasonably rapid load current changes are to be achieved.

5-31 A mercury-wetted relay, as connected in the load switching circuit of Figure 5-5 should be used for loading and unloading the supply. When this load switch is connected to a 60Hz ac input, the mercury-wetted relay will open and close 60 times per second. Adjustment of the 25K control permits adjustment of the duty cycle of the load current switching and reduction in jitter of the oscilloscope display.

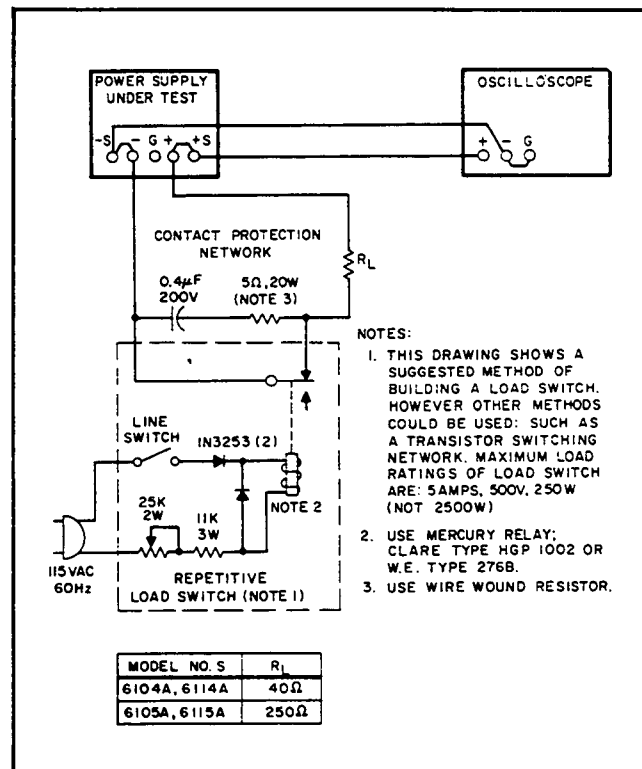

Figure 5-5. Transient Recovery Time Test Setup

5-32 To check the transient recovery time, proceed as follows:

- a. Connect test setup shown in Figure 5-5.
- b. Turn CURRENT control fully clockwise.
- c. Turn on supply and adjust VOLTAGE control until front panel ammeter indicates maximum rated output current.
- d. Close line switch on repetitive load switch setup.
- e. Set oscilloscope for internal sync and lock on either positive or negative load transient spike.
- f. Set vertical input of oscilloscope for ac coupling so that small dc level changes in power supply output voltage will not cause display to shift.
- g. Adjust the vertical centering on the scope so that the tail ends of the no load and full load waveforms are symmetrically displayed about the horizontal center line of the oscilloscope. This center line now represents the nominal output voltage defined in the specification.
- h. Adjust the horizontal positioning control so that the trace starts at a point coincident with a major graticule division. This point is then representative of time zero.
- i. Increase the sweep rate so that a single transient spike can be examined in detail.
- j. Adjust the sync controls separately for the positive and negative going transients so that not only the recovery waveshape but also as much as possible of the rise time of the transient is displayed.
- k. Starting from the major graticule division representative of time zero, count to the right $50\mu\text{sec}$ and vertically 10mV . Recovery should be within these tolerances as illustrated in Figure 5-6.

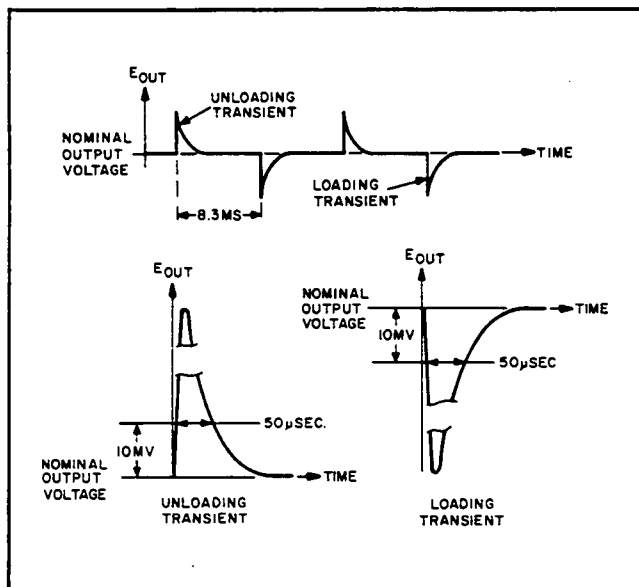

Figure 5-6. Transient Recovery Time, Waveforms

5-33 Temperature Coefficient.

Definition: The change in output voltage per degree Centigrade change in the ambient temperature under conditions of constant input ac line voltage, output voltage setting, and load resistance.

5-34 The temperature coefficient of a power supply is measured by placing the power supply in an oven and varying it over any temperature span within its rating. (Most HP power supplies are rated for operation from 0°C to 55°C .) The power supply must be allowed to thermally stabilize for a sufficient period of time at each measurement temperature.

5-35 The temperature coefficient given in the specifications is the maximum temperature-dependent output voltage change which will result over any one degree Centigrade interval. The differential voltmeter or digital voltmeter used to measure the output voltage change of the supply should be placed outside the oven and should have a long term stability adequate to insure that its drift will not affect the overall measurement accuracy.

5-36 To check the temperature coefficient, proceed as follows:

- a. Connect load resistance (full voltage/half current) and differential voltmeter as illustrated in Figure 5-2.

NOTE

Connect voltmeter to $\pm\text{S}$ terminals, NOT across load.

- b. Turn CURRENT controls fully clockwise.
- c. Adjust front panel VOLTAGE controls until front panel voltmeter indicates maximum rated output voltage.
- d. Place power supply in temperature-controlled oven (differential voltmeter and load remains outside oven). Set temperature to 30°C and allow 30 minutes warm-up.
- e. Record differential voltmeter reading.
- f. Raise temperature to 40°C and allow 30 minutes warm-up.
- g. Observe differential voltmeter reading.

Difference in voltage reading between Step (e) and (g) should be less than the following:

- 6104A - 2.025mV
- 6105A - 5.05mV
- 6114A - .415mV
- 6115A - 1.015mV

5-37 Drift (Output Stability).

Definition: The change in output voltage

for the first eight hours following a 30-minute warm-up period. During the interval of measurement all parameters, such as load resistance, ambient temperature, and input line voltage are held constant.

5-38 This measurement is made by monitoring the output of the power supply on a differential voltmeter or digital voltmeter over the stated measurement interval; a strip chart recorder can be used to provide a permanent record. A thermometer should be placed near the supply to verify that the ambient temperature remains constant during the period of measurement. The supply should be put in a location immune from stray air currents (open doors or windows, air conditioning vents); if possible, the supply should be placed in an oven which is held at a constant temperature. Care must be taken that the measuring instrument has a stability over the eight hour interval which is at least an order of magnitude better than the stability specification of the power supply being measured. The supply will drift considerably less over the eight hour measurement interval than during the half-hour warm-up.

5-39 To check the output stability, proceed as follows:

- Connect load resistance (full voltage/half current) and differential voltmeter as illustrated in Figure 5-2.
- Turn CURRENT control fully clockwise.
- Adjust front panel VOLTAGE control until differential voltmeter indicates maximum rated output voltage.
- Allow 30 minutes warm-up, then record differential voltmeter reading.
- After 8 hours, differential voltmeter should change from reading recorded in Step (d) by less than the following:

| | | |
|-----------------|---|--------------------------------------------|
| 6104A - 2.05mV | } | See Table 1-1 for an important note. |
| 6105A - 5.05mV | | |
| 6114A - .615mV | | |
| 6115A - 1.515mV | | |

5-40 Output Impedance.

Definition: At any given frequency of load change, $\Delta E_{OUT}/\Delta I_{OUT}$. Strictly speaking the definition applies only for a sinusoidal load disturbance, unless, of course, the measurement is made at zero frequency (DC). The output impedance of an ideal constant voltage power supply would be zero at all frequencies, while the output impedance for an ideal constant current power supply would be infinite at all frequencies.

The output impedance of a power supply is normally not measured, since the measurement of transient

recovery time reveals both the static and dynamic output characteristics with just one measurement. The output impedance of a power supply is commonly measured only in those cases where the exact value at a particular frequency is of engineering importance.

5-41 To check the output impedance, proceed as follows:

- Connect test setup shown in Figure 5-7.
- Set METER SELECTION switch to VOLTS position.
- Turn on supply and adjust VOLTAGE control until front panel meter reads maximum rated output voltage.
- Set AMPLITUDE control on Oscillator to 10 Volts (E_{in}), and FREQUENCY control to desired frequency.
- Record voltage across output terminals of the power supply (E_o) as indicated on AC voltmeter.
- Calculate the output impedance by the following formula:

$$Z_{out} = \frac{E_o R}{E_{in} - E_o}$$

E_o = rms voltage across power supply output terminals.

$R = 1000$

$E_{in} = 10$ Volts

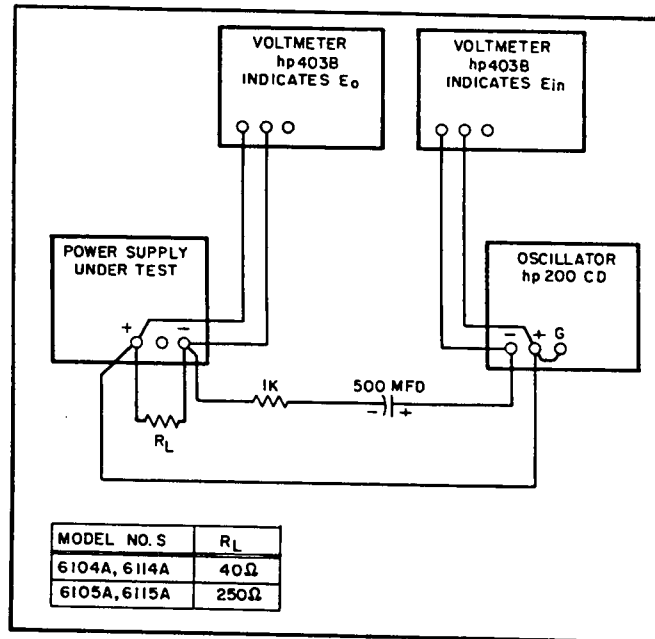

Figure 5-7. Output Impedance, Test Setup

5-42 CONSTANT CURRENT TESTS

5-43 The instruments, methods, and precautions for the proper measurement of constant current power supply characteristics are for the most part identical to those already described for the measurement of constant voltage power supplies. There

are, however, two main differences: First, the power supply performance will be checked between short circuit and full load rather than open circuit and full load. Second, a current monitoring resistor is inserted between the output of the power supply and the load.

5-44 For all output current measurements the current sampling resistor must be treated as a four terminal device. In the manner of a meter shunt, the load current is fed to the extremes of the wire leading to the resistor while the sampling terminals are located as close as possible to the resistance portion itself (see Figure 5-8). Generally, any current sampling resistor should be of the low noise, low temperature coefficient (less than 20ppm/°C) type and should be used at no more than 10% of its rated power so that its temperature rise will be minimized.

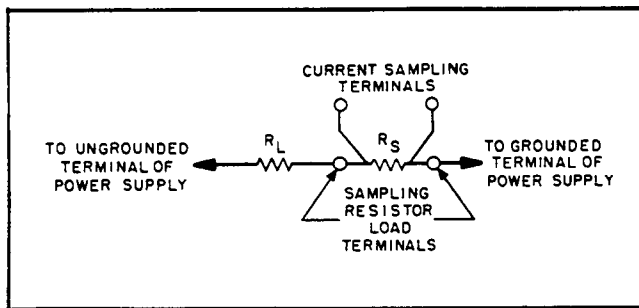

Figure 5-8. Current Sampling Resistor Connections

5-45 Rated Output and Meter Accuracy.

- Connect test setup shown in Figure 5-9.
- Turn VOLTAGE control fully clockwise.
- Turn on supply and adjust CURRENT control until front panel ammeter indicates maximum rated output current.
- Differential voltmeter should read as follows:

6104A/6114A - .2V±4mV
6105A/6115A - .08V±1.6mV

5-46 Line Regulation.

Definition: The change ΔI_{OUT} in the static value of dc output current resulting from a change in ac input voltage over the specified range from low line (usually 103.5 volts) to high line (usually 126.5 volts), or from high line to low line.

To check the line regulation, proceed as follows:

- Utilize test setup shown in Figure 5-9.
- Connect variable auto transformer between input power source and power supply power input.
- Adjust auto transformer for 103.5Vac input.
- Turn VOLTAGE control fully clockwise.

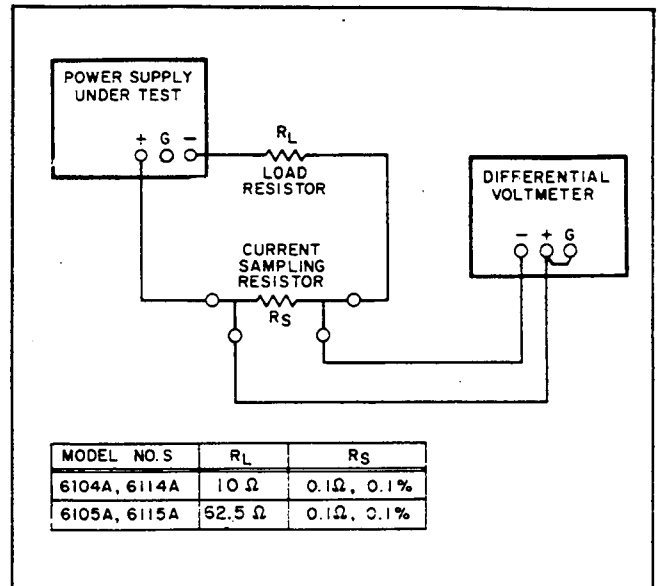

Figure 5-9. Constant Current Load Regulation Test Setup

- Adjust CURRENT control until front panel ammeter reads exactly maximum rated output current.

- Read and record voltage indicated on differential voltmeter.

- Adjust variable auto transformer for 126.5Vac input.

- Reading on differential voltmeter should not vary from reading recorded in Step (f) by more than the following:

6104A/6114A - .2V±14μV
6105A/6115A - 8mV±2.4μV

5-47 Load Regulation.

Definition: The change ΔI_{OUT} in the static value of the dc output current resulting from a change in load resistance from short circuit to a value which yields maximum rated output voltage.

5-48 To check the constant current load regulation, proceed as follows:

- Connect test setup shown in Figure 5-9.
- Turn VOLTAGE control fully clockwise.
- Adjust CURRENT control until front panel meter reads exactly maximum rated output voltage.
- Read and record voltage indicated on differential voltmeter.

- Short circuit load resistor (R_L).
- Reading on differential voltmeter should not vary from reading recorded in Step (d) by more than the following:

6104A/6114A - .2V±70μV
6105A/6115A - .008V±50.8μV

5-49 Ripple and Noise.

Definition: The residual ac current which is superimposed on the dc output current of a regulated power supply. Ripple and noise may be specified and measured in terms of its RMS or (preferably) peak-to-peak value.

also apply to the measurement of constant current ripple and noise. Figures 5-10 and 5-13 illustrate the most important precautions to be observed when measuring the ripple and noise of a constant current supply. The presence of a 120Hz waveform on the oscilloscope is normally indicative of a correct measurement method. A waveshape having 60Hz as its fundamental component is typically associated with an incorrect measurement setup.

5-51 Ripple Measurement. To check the output ripple, proceed as follows:

- Connect the oscilloscope as shown in Figures 5-10B or 5-10C.
- Rotate the VOLTAGE control fully cw,
- If necessary, set METER switch to mA and turn on supply.
- Adjust CURRENT control until front panel meter reads exactly the maximum rated output current.
- The observed ripple should be less than $100\mu\text{V}$ p-p.

5-52 Noise Spike Measurement. To check the noise spike output, proceed as follows:

- Connect test setup shown in Figure 5-11.
- Turn VOLTAGE control fully clockwise.
- Adjust CURRENT control until front panel ammeter indicates exactly rated output current.
- The observed noise spikes should be less than $50\mu\text{V}$ p-p (the impedance matching resistors constitute a 2:1 divider).

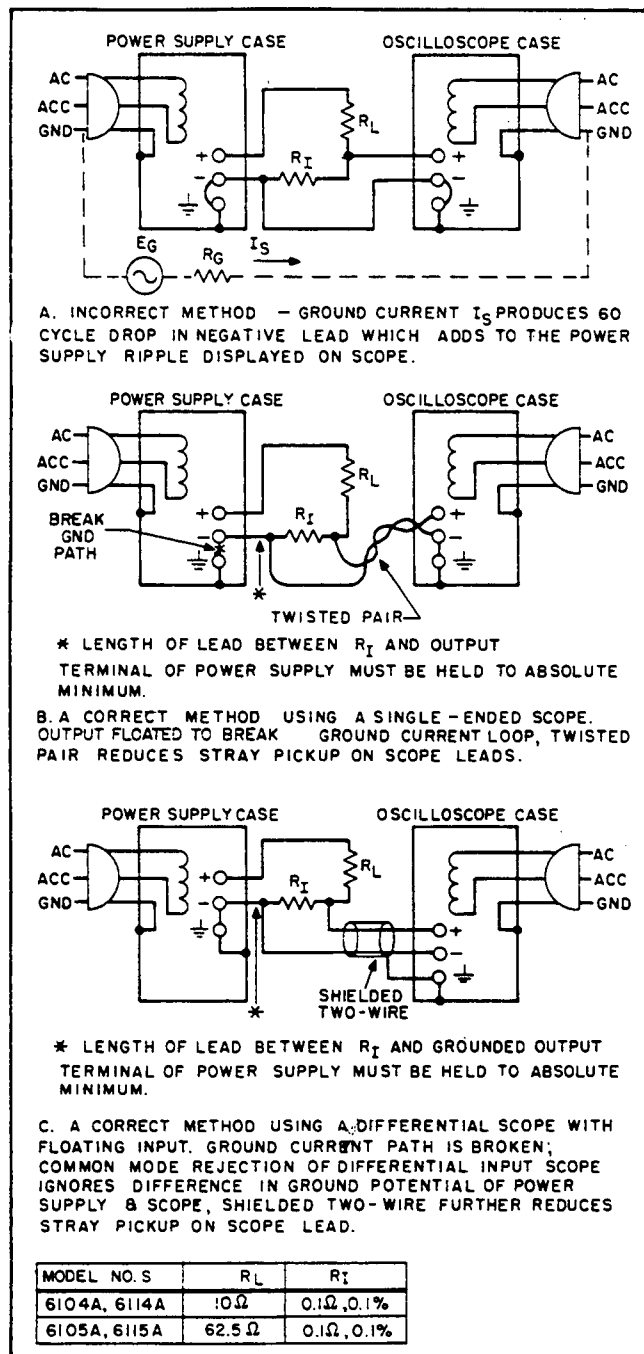

Figure 5-10. CC Ripple and Noise Test Setup

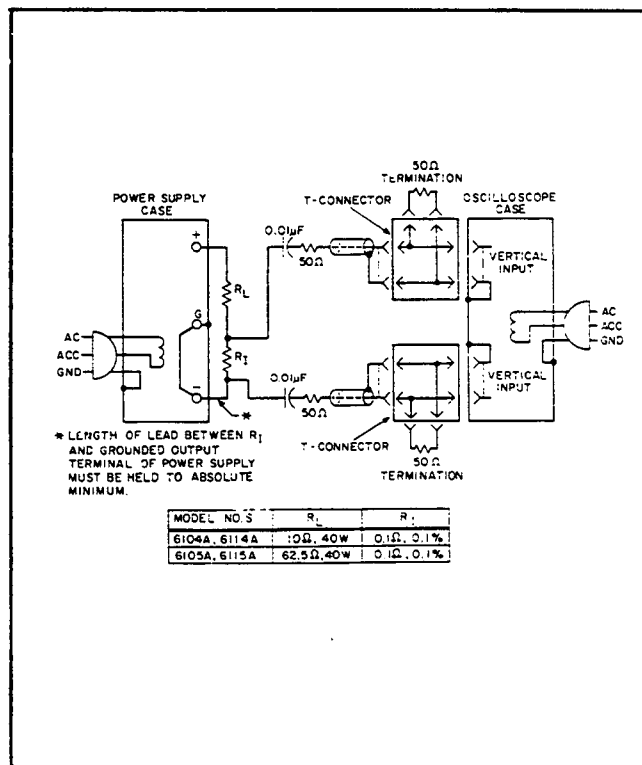

Figure 5-11. Constant Current Noise Spike Test Setup

5-50 Most of the instructions pertaining to the ground loop and pickup problems associated with constant voltage ripple and noise measurements

5-53 TROUBLESHOOTING

WARNING

The following troubleshooting procedures are performed with power applied to the supply while its protective covers are removed. Be careful when performing the procedures as line voltage is always present on the power input connector, fuse holder, and in the power supply rectifier circuits. In addition, when the supply is on, energy available at many points, particularly the power transistors on the rear heat sink, may result in personal injury or death when contacted.

5-54 Before attempting to troubleshoot this instrument, ensure that the fault is with the instrument and not with an associated circuit. The performance test (Paragraph 5-5) enables this to be determined without removing the instrument's covers.

5-55 A good understanding of the principles of operation is a helpful aid in troubleshooting, and it is recommended that the reader review Section IV of the manual before attempting to troubleshoot the instrument. Once the principles of operation are understood, refer to the overall troubleshooting procedure in Paragraph 5-58 to locate the symptom and its probable cause.

5-56 The schematic diagrams at the rear of the manual (Figures 7-4 and 7-5) contain normal voltage readings taken at various points within the circuits. These voltages (in italics) are positioned adjacent to the applicable test points (identified by encircled numbers). The component location diagrams (Figures 7-1 through 7-3) at the rear of the manual should be consulted to determine the location of components and test points.

5-57 If a defective component is located, replace it and re-conduct the performance test. When a component is replaced, refer to the repair and replacement (Paragraph 5-70) and adjustment and calibration (Paragraph 5-83) sections of this manual.

CAUTION

If the power supply output voltage DOES NOT respond as programmed, DO NOT program zero volts output. Damage to the constant voltage comparator can result.

5-58 OVERALL TROUBLESHOOTING PROCEDURE

5-59 It is important that the following procedure be followed in sequence when initially troubleshooting the instrument. Make all power supply settings as instructed.

a. With power off, check for obvious troubles such as blown main fuse (F1), 115/230V line switch in wrong position, incorrect rear strapping pattern, input power failure, or defective meter (check output voltage with external meter).

b. Remove top, bottom, and side covers and inspect for open connections, charred components, etc.

c. Turn OVERVOLTAGE control (screwdriver) maximum clockwise.

d. Program voltage for one half of maximum.

NOTE

Normal troubleshooting procedures are based on driving the series regulator into saturation or cutoff by opening or shorting a previous stage. For a detailed explanation of this, refer to Service Note M-33 (D. C. Detective).

CAUTION

DO NOT try this procedure on the Series Regulator (Q2, Q3) or Driver (Q4) as damage to these circuits may occur.

e. Check that there is at least $10M\Omega$ between either the + or - output terminal and chassis ground. If resistance measures less than $10M\Omega$, check supply for internal leakage current to chassis ground. If $10M\Omega$ were measured, continue with procedure.

f. With no load connected, turn ON the power supply. If OVERVOLTAGE indicator comes on (crowbar tripped), turn off supply and disable the crowbar by disconnecting (unsoldering) one end of A1R34.

g. Check the reference and bias voltages given in Table 5-2. (See Paragraph 5-60.)

5-60 In many cases, trouble can be caused by incorrect dc bias voltages; thus it is good practice to check these voltages before proceeding with any of the detailed troubleshooting procedures. When troubleshooting a supply with multiple failures, in which curing one trouble often uncovers another, it is a good idea to check the reference voltages

whenever a new symptom occurs. In many cases the reference voltages may be incorrect even though all the components in the reference regulator are functional; this may occur because a defective component or stage in the regulator feedback loop is drawing excessive current and loading down the reference voltages. In this situation the defective stage can usually be located by following the detailed troubleshooting procedure appropriate for the main symptom (high or low output voltage, etc.).

Table 5-2. Reference and Bias Voltages (Refer to Schematic for Test Point Locations)

| STEP | METER COMMON | METER POSITIVE | NORMAL READING | CHECK IF NOT CORRECT |
|------|--------------|----------------|----------------|----------------------|
| 1 | +S | 15 | 16±.016V | A2Q1, A2Q2, A2VR1 |
| 2 | +S | 20 | 7.5±.6V | A1VR3, A1VR4, A1VR5, |
| 3 | +S | 21 | 3±.4V | A1VR3, A1VR4, A1VR5 |
| 4 | 17 | +S | 14.7±1V | VR3 |
| 5 | 22 | +S | 4.3±.26V | A1VR3, A1VR4, A1VR5 |
| 6 | +S | 18 | 6.2±.31V | A2VR4 |

5-61 After completing the initial troubleshooting checks above, continue troubleshooting according to the symptoms you have noted. The following troubleshooting procedures are separated into two major sections: major problems and specification problems. The procedure (Paragraph 5-62) for troubleshooting major problems (such as zero output voltage or maximum output current) includes a troubleshooting tree that either isolates the problem to the probable faulty component(s) or it references more detailed test procedures. The specification problems are isolated using troubleshooting table (Paragraph 5-68). Note that if you cannot locate your symptoms on the troubleshooting tree or in the specification troubleshooting table, check out the crowbar circuit (Paragraph 5-64) and current capability of the supply (Paragraph 5-66).

5-62 MAJOR PROBLEMS

5-63 Figure 5-12 is a troubleshooting tree organized according to trouble symptoms that indicate the supply has a major fault. The troubleshooting tree assumes that the power supply is initially

set-up according to the initial troubleshooting procedures (Paragraph 5-59). That is:

1. The power supply is programmed for half maximum voltage and the CURRENT control is set maximum counterclockwise (no current programmed).
2. No load is connected to the power supply.
3. The OVERVOLTAGE control is set maximum clockwise and the crowbar either did not trip when power was applied or, if it did, it was disabled (A1R34 disconnected, see Paragraph 5-59, step f). With the above initial conditions established, proceed to the troubleshooting tree, Figure 5-12.

5-64 OVERVOLTAGE CROWBAR CHECKOUT AND TROUBLESHOOTING

5-65 Perform the following procedures to check the overvoltage crowbar circuit.

- a. If the crowbar was disabled in paragraph 5-59, step f, reconnect A1R34 and attempt to operate the supply without tripping the crowbar. If the crowbar was not disabled, check out the crowbar by setting the supply to half voltage and current (with no load) and rotating the OVERVOLTAGE control counterclockwise until the crowbar trips (OVERVOLTAGE and CURRENT MODE indicators come on). Next, shut off the supply and program output voltage to +10 volts. Turn the supply back on and verify that the crowbar does not trip again.
- b. If the crowbar is always on (won't reset), check A1CR20 for a short.
- c. If the crowbar won't trip, check:
 1. A1CR20 for open
 2. A1CR18 for short
 3. A1V1 and associated components.
- d. If the crowbar trips normally, measure the voltage at TP20 (with respect to +S). If the voltage is not approximately +2V, check A1CR16 for open.

5-66 OUTPUT CURRENT CHECKOUT AND TROUBLESHOOTING

5-67 Assuming the initial troubleshooting procedures (Paragraph 5-59) and the major problem troubleshooting tree (Figure 5-12) have not helped in isolating the problem, check the output current capability of the supply using the following procedures:

- a. Connect a load resistor to the output terminals as follows:
 - 6104A/6114A - 40 Ω (1A current range rating)
 - 6105A/6115A - 250 Ω (.4A current range rating)
- b. Adjust the CURRENT control from 0 to about half maximum rating. The output voltage and current should follow the programming (CURRENT MODE indicator comes on if supply enters constant current mode). If the supply is not capable of providing rated output current, check the constant current source (A2Q4, A2Q5, A2VR2), A2CR2, A2CR3, A2CR4, and the constant current comparator A2U3.

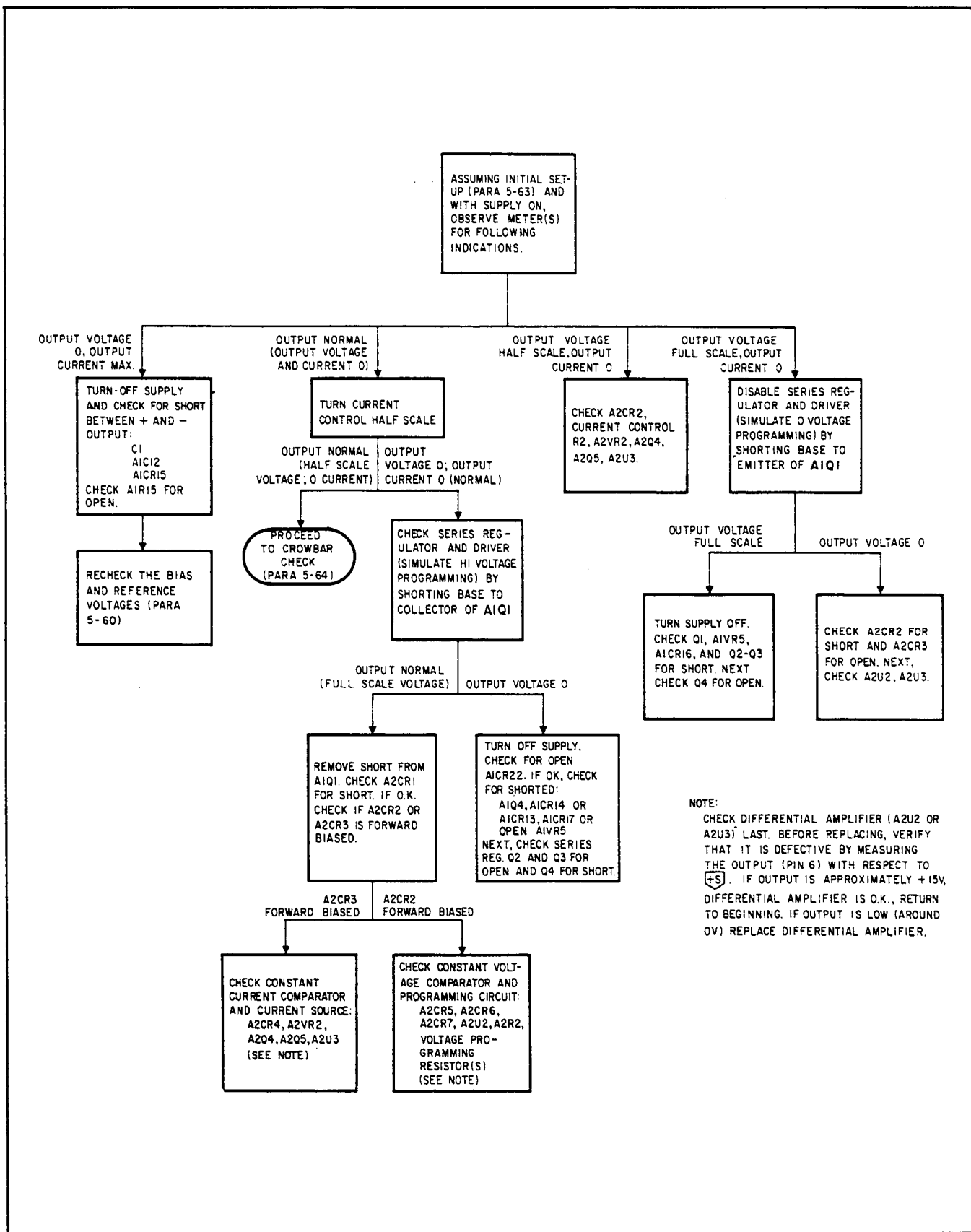

Figure 5-12. Major Problems, Troubleshooting Tree

If current is O.K., continue to step c.

c. Connect a load resistor to output terminals as follows:

6104A/6114A - 10 Ω (2A current range rating)

6105A/6115A - 62.5 Ω (.8A current range rating)

d. Adjust the CURRENT control from 0 to full output current rating. Output current should follow the CURRENT adjustment from 0 to full rating. Output voltage will be limited to half maximum rating. If the supply is not capable of providing the full current rating, check the adjustment of A1R7, and the series regulator components A1CR11, A1CR12,

A1VR3, A1VR4, A1VR2, Q1, A1VR5, Q2 and Q3.

5-68 SPECIFICATION PROBLEMS

5-69 Table 5-3 contains a list of less common troubles and their possible causes. The troubles in this table are less catastrophic than those previously described in that, generally, they lead to degraded performance rather than complete failure. The possible causes listed should be checked in the order they appear in the table.

Table 5-3. Specification Problems

| SYMPTOM | PROBABLE CAUSE AND RECOMMENDED ACTION |
|--------------------------------------------------|-------------------------------------------------------------------------------------------------------------------------------------------------------------------------------------------------------------------------------------------------------------------------------------------------------------------------------------------------------------------------------------------------------------------------------------------------------------------------------------------------------------------------------------------------------------------------------------------------------------------------------------------------------------------------------------------------|
| Poor Constant Voltage Line Regulation (No Load) | Reference Supply. Check A2VR1, A2VR3, A2VR4, A2U1, A2Q1, A2Q2, A2CR1 |
| Poor Constant Current Line Regulation | a. Reference Supply. Check A2VR1, A2VR2, A2VR3, A2VR4, A2CR1, A2U1, A2Q1, A2Q2. b. Constant Current Source. Check A2Q4, A2Q5. |
| Poor Constant Voltage Load Regulation | a. Constant current limit defective or set too low. b. Gross current limit defective or adjusted low (see calibration procedure, paragraph 5-87). c. Check A2CR5, A2CR6, A2CR7, A2U2, A2Q2, A2Q3. |
| Poor Constant Current Load Regulation | a. Gross current limit defective or set low (see calibration procedure, paragraph 5-87). b. Check for defective A1CR15, A1C12, C1, A1CR20. c. Check A2Q4, A2Q5, A2VR2, A2U3, A2CR4, A2CR3. |
| Poor Programming Accuracy (6114A and 6115A ONLY) | Program unit up from zero and note output voltage. a. If the error in the output voltage increases linearly, check Voltage Programming Adjustment (see paragraph 5-89). b. If output voltage programs correctly until some point is reached at which a large error is noted, check the last programming resistor(s) switched in. |
| High Ripple | a. 60Hz Ripple: 1. Ground loop thru test equipment, check test set up. 2. Open filter capacitor, check A1C4, A1C8. 3. Defective rectifier, check A1CR7 - A1CR10. b. 120Hz Ripple: 1. Ground loop thru test equipment, check test set up. 2. Open output capacitor, check A1C12. 3. Excessive ripple in reference voltages, check reference supply rectifier (A1CR1-A1CR4, A1C1, A1C2). 4. Supply crossing over to constant current operation under loaded conditions, check setting of CURRENT control (may be set too close to operating output current point). c. High Frequency Noise (GRASS): Noisy zener diodes in reference supply, check A2VR1, A2VR3, A2VR4. |

5-70 REPAIR AND REPLACEMENT

5-71 Section VI of this manual contains a list of replaceable parts. If the part to be replaced does not have a standard manufacturers' part number, it is a "special" part and must be obtained directly from Hewlett-Packard. After replacing any semiconductor device, refer to the adjustment procedures outlined later in this Section.

5-72 COVERS

5-73 Top or Bottom Cover. To remove either the top or bottom cover:

- a. Turn off unit.
- b. Remove two, 1/2-inch #6 self-tapping flat-head screws at rear of cover.
- c. Slide cover toward rear of unit approximately 3/4 inches and lift out of unit.

5-74 Side Cover. To remove either side cover, remove four, 1/4-inch, #6 flat-head screws and lift cover off.

5-75 PUSHBUTTON SWITCH ASSEMBLY (6114A/6115A), METER(S), AND FRONT PANEL

5-76 To remove the pushbutton switch assembly (if applicable), meter(s), and front panel, proceed as follows:

- a. Remove all covers (see Paragraph 5-72).
- b. Remove screws at each end of top trim strip.
- c. For 6114A and 6115A supplies, remove screw on right side of chassis (supporting pushbutton switch assembly). The 6104A and 6105A supplies do not have this screw.
- d. Lift top trim strip up. Meters or meter and pushbutton switch assembly are mounted on the trim strip.
- e. Slide meter(s)/switch assembly out of trim strip.
- f. Disconnect leads to switch assembly which can now be completely removed for replacement of:
 1. Entire assembly.
 2. Switch assembly potentiometer R21.
 3. Resistors mounted on Resistor Board A3.
- g. Remove #6 screw securing each side-to-bottom cross member. Front panel can now be lifted out.

5-77 REAR HEAT SINK ASSEMBLY

5-78 In order to remove the power transistors (Q1 through Q4) from the heat sink, the rear panels must first be removed. After the rear panels are removed, the transistors are exposed and can be removed. Notice that if a new power transistor is installed, be sure to apply silicon grease (Dow

DC-5, HP 8500-0059) to both sides of the transistor's mica insulator to assure proper heat exchange.

5-79 Rear Panels. To remove the rear panel containing the rear terminal boards and the panel containing the power receptacle, proceed as described below.

5-80 Terminal Board Panel.

- a. Remove top cover (Paragraph 5-73).
- b. Remove two screws at top of unit (near Service tag).
- c. Lift the panel straight up and out.

5-81 Power Receptacle Panel.

- a. Remove bottom cover (Paragraph 5-73).
- b. Remove two screws securing corner of panel.
- c. Lift panel straight up and out.

5-82 Heat Sink. To remove the heat sink, proceed as follows:

- a. Remove all covers (Paragraph 5-72).
- b. Remove terminal board and power receptacle rear panels (see above).
- c. Remove four screws securing heat sink to side frames. The heat sink can now be lifted out.

5-83 ADJUSTMENT AND CALIBRATION

5-84 Adjustment and calibration may be required after performance testing, troubleshooting, or repair and replacement. Usually, only those adjustments that affect the operation of the faulty circuit need be performed.

5-85 METER ZERO

5-86 The meter pointer must rest on the zero calibration mark on the meter scale when the instrument is at normal operating temperature, resting in its normal operating position, and turned off. To zero set the meter proceed as follows:

- a. Turn on instrument and allow it to come up to normal operating temperature (about 30 minutes).
- b. Turn instrument off. Wait one minute for power supply capacitors to discharge completely.
- c. Insert sharp pointed object (pen point or awl) into small indentation near top of round black plastic disc located directly below meter face.
- d. Rotate plastic disc clockwise until meter reads zero, then rotate counterclockwise slightly in order to free adjustment screw from meter suspension. Pointer should not move during latter part of adjustment.

5-87 GROSS CURRENT LIMIT ADJUSTMENT

5-88 The supply should enter the gross current

limit region when output voltage is set above one-half maximum rating and current exceeds one-half maximum rating. The gross current limit is set to operate at approximately 60% of the maximum current rating of the supply (using low line input).

a. Connect power supply to an ac variac.
b. Turn the front panel CURRENT control maximum clockwise.

c. Connect a variable resistance load across the output terminals as follows:

Nominal Load Resistance

6104A/6114A - 33 ohms, 50 watts

6105A/6115A - 200 ohms, 50 watts

d. Program output voltage for maximum rating.

6104A/6114A - 40V

6105A/6115A - 100V

e. Adjust variac for 103 volts ac.

f. Adjust A1R7 so the CURRENT MODE light just turns on at 60% of maximum rated current as given below:

6104A/6114A - 1.2 amps

6105A/6115A - .48 amps

5-89 CONSTANT VOLTAGE PROGRAMMING ACCURACY

5-90 Reference Supply. To calibrate the +16V reference supply, proceed as follows:

a. Turn on the supply and allow a 30-minute warm up.

b. Measure voltage across A2VR1 (TP17 to ).

1. If voltage is +6V or less, insert a 408.2Ω resistor (R3) in place of jumper between A2R8A and A2R9 (use HP Part No. 0811-2762 or equivalent).
2. If voltage is greater than +6V, leave R3 jumper installed.

5-91 Zero Output Voltage.

a. Connect differential voltmeter between +S and -S.

b. Short-out VOLTAGE control by connecting jumper between TB1-A1 and -S.

c. Adjust A2R13 for a reading of $-450 \pm 50 \mu\text{V}$ on voltmeter.

d. Remove short from A1 to -S.

5-92 Voltage Programming Current.

a. Turn power supply off.

b. With supply connected for normal strapping (see Figure 3-2), remove jumper between TB1-A2 and -A3.

c. Connect a precision 1KΩ calibration resistor (JRL NB103 or equivalent) from TB1-A1 to -S.

d. Connect a 10MΩ input impedance differential voltmeter across the 1KΩ precision resistor.

NOTE

Calibration errors may result if a differential voltmeter with less than 10MΩ input impedance is used.

e. Turn on power supply.

f. Adjust A2R5 for a reading of $0.5 \pm 5 \mu\text{V}$ on the voltmeter.

g. Turn supply off and replace jumper from TB1-A2 to -A3.

5-93 Voltmeter Calibration.

a. Connect differential voltmeter between +S and -S.

b. Turn supply on.

c. Program power supply for full output voltage as follows:

6104A/6114A - $40\text{V} \pm 10\text{mV}$

6105A/6115A - $100\text{V} \pm 20\text{mV}$

d. Adjust A1R22 so that front panel voltmeter reads within $\pm 2\%$ of output voltage.

5-94 CONSTANT CURRENT PROGRAMMING ACCURACY

5-95 Zero Output Current.

a. Turn power supply on.

b. Program output voltage for 2 volts.

c. Short-out CURRENT control by connecting jumper from TB1-A6 to + output.

d. Connect a 1ohm $\pm .1\%$ resistor across the output terminals.

e. Connect differential voltmeter across the 1 ohm load resistor.

f. Adjust A2R12 to read $0 \pm 10 \mu\text{V}$ on differential voltmeter.

g. Turn supply off.

h. Remove short from TB1-A6 to + output.

5-96 Current Programming Current.

a. Turn off supply and remove jumper between TB1-A6 and -A7.

b. Connect 0.1Ω load across output.

c. Connect a precision (JRL NB103) 1KΩ resistor between TB1-A6 to + output.

d. Connect differential voltmeter across output terminals.

e. Program supply for 2 volts and turn on supply.

f. Adjust A2R19 for a differential voltmeter reading as follows:

6104A/6114A - $0.2\text{V} \pm 500 \mu\text{V}$

6105A/6115A - $0.1\text{V} \pm 250 \mu\text{V}$

NOTE

The ammeter calibration procedure to the right uses the same test set up.

g. Turn supply off. Replace jumper between TB1-A6 and -A7 and remove precision resistor and voltmeter.

5-97 Ammeter Calibration.

a. Connect power supply test set up as given in Paragraph 5-96.

b. Adjust A1R17 so that front panel current meter reads:

6104A/6114A - 2A \pm 1%

6105A/6115A - 1A \pm 1%

c. Turn supply off.

d. Remove precision 1K Ω resistor.

e. Connect jumper between TB1-A6 and -A7.

SECTION VI REPLACEABLE PARTS

6-1 INTRODUCTION

6-2 This section contains information for ordering replacement parts. Table 6-4 lists parts in alpha-numeric order by reference designators and provides the following information:

- a. Reference Designators. Refer to Table 6-1.
- b. Description. Refer to Table 6-2 for abbreviations.
- c. Total Quantity (TQ). Given only the first time the part number is listed except in instruments containing many sub-modular assemblies, in which case the TQ appears the first time the part number is listed in each assembly.
- d. Manufacturer's Part Number or Type.
- e. Manufacturer's Federal Supply Code Number. Refer to Table 6-3 for manufacturer's name and address.
- f. Hewlett-Packard Part Number.
- g. Recommended Spare Parts Quantity (RS) for complete maintenance of one instrument during one year of isolated service.
- h. Parts not identified by a reference designator are listed at the end of Table 6-4 under Mechanical and/or Miscellaneous. The former consists of parts belonging to and grouped by individual assemblies; the latter consists of all parts not immediately associated with an assembly.

6-3 ORDERING INFORMATION

6-4 To order a replacement part, address order or inquiry to your local Hewlett-Packard sales office (see lists at rear of this manual for addresses). Specify the following information for each part: Model, complete serial number, and any Option or special modification (J) numbers of the instrument; Hewlett-Packard part number; circuit reference designator; and description. To order a part not listed in Table 6-4, give a complete description of the part, its function, and its location.

Table 6-1. Reference Designators

| | |
|-------------------------------|-------------------|
| A = assembly | E = miscellaneous |
| B = blower (fan) | electronic part |
| C = capacitor | F = fuse |
| CB = circuit breaker | J = jack, jumper |
| CR = diode | K = relay |
| DS = device, signaling (lamp) | L = inductor |
| | M = meter |

Table 6-1. Reference Designators (Continued)

| | |
|---------------------|---------------------------------------------|
| P = plug | V = vacuum tube, neon bulb, photocell, etc. |
| Q = transistor | |
| R = resistor | |
| S = switch | VR = zener diode |
| T = transformer | X = socket |
| TB = terminal block | Z = integrated circuit or network |
| TS = thermal switch | |

Table 6-2. Description Abbreviations

| | |
|----------------------------------|----------------------------------|
| A = ampere | mfr = manufacturer |
| ac = alternating current | mod. = modular or modified |
| assy. = assembly | mtg = mounting |
| bd = board | n = nano = 10^{-9} |
| bkt = bracket | NC = normally closed |
| °C = degree Centigrade | NO = normally open |
| cd = card | NP = nickel-plated |
| coef = coefficient | Ω = ohm |
| comp = composition | obd = order by description |
| CRT = cathode-ray tube | OD = outside diameter |
| CT = center-tapped | p = pico = 10^{-12} |
| dc = direct current | P.C. = printed circuit |
| DPDT = double pole, double throw | pot. = potentiometer |
| DPST = double pole, single throw | p-p = peak-to-peak |
| elect = electrolytic | ppm = parts per million |
| encap = encapsulated | pvr = peak reverse voltage |
| F = farad | rect = rectifier |
| °F = degree Fahrenheit | rms = root mean square |
| fxd = fixed | Si = silicon |
| Ge = germanium | SPDT = single pole, double throw |
| H = Henry | SPST = single pole, single throw |
| Hz = Hertz | SS = small signal |
| IC = integrated circuit | T = slow-blow |
| ID = inside diameter | tan. = tantalum |
| incnd = incandescent | Ti = titanium |
| k = kilo = 10^3 | V = volt |
| m = milli = 10^{-3} | var = variable |
| M = mega = 10^6 | ww = wirewound |
| μ = micro = 10^{-6} | W = Watt |
| met. = metal | |

Table 6-3. Code List of Manufacturers

| CODE NO. | MANUFACTURER | ADDRESS |
|----------|----------------------------------------------------------------|-----------------------|
| 00629 | EBY Sales Co., Inc. | Jamaica, N. Y. |
| 00656 | Aerovox Corp. | New Bedford, Mass. |
| 00853 | Sangamo Electric Co. S. Carolina Div. | Pickens, S. C. |
| 01121 | Allen Bradley Co. | Milwaukee, Wis. |
| 01255 | Litton Industries, Inc. | Beverly Hills, Calif. |
| 01281 | TRW Semiconductors, Inc. | Lawndale, Calif. |
| 01295 | Texas Instruments, Inc. Semiconductor-Components Div. | Dallas, Texas |
| 01686 | RCL Electronics, Inc. | Manchester, N. H. |
| 01930 | Amerock Corp. | Rockford, Ill. |
| 02107 | Sparta Mfg. Co. | Dover, Ohio |
| 02114 | Ferroxcube Corp. | Saugerties, N. Y. |
| 02606 | Fenwal Laboratories | Morton Grove, Ill. |
| 02660 | Amphenol Corp. | Broadview, Ill. |
| 02735 | Radio Corp. of America, Solid State and Receiving Tube Div. | Somerville, N. J. |
| 03508 | G. E. Semiconductor Products Dept. | Syracuse, N. Y. |
| 03797 | Eldema Corp. | Compton, Calif. |
| 03877 | Transitron Electronic Corp. | Wakefield, Mass. |
| 03888 | Pyrofilm Resistor Co. Inc. | Cedar Knolls, N. J. |
| 04009 | Arrow, Hart and Hegeman Electric Co. | Hartford, Conn. |
| 04072 | ADC Electronics, Inc. | Harbor City, Calif. |
| 04213 | Caddell & Burns Mfg. Co. Inc. | Mineola, N. Y. |
| 04404 | *Hewlett-Packard Co. Palo Alto Div. | Palo Alto, Calif. |
| 04713 | Motorola Semiconductor Prod. Inc. | Phoenix, Arizona |
| 05277 | Westinghouse Electric Corp. Semiconductor Dept. | Youngwood, Pa. |
| 05347 | Ultronix, Inc. | Grand Junction, Colo. |
| 05820 | Wakefield Engr. Inc. | Wakefield, Mass. |
| 06001 | General Elect. Co. Electronic Capacitor & Battery Dept. | Irmo, S. C. |
| 06004 | Bassik Div. Stewart-Warner Corp. | Bridgeport, Conn. |
| 06486 | IRC Div. of TRW Inc. Semiconductor Plant | Lynn, Mass. |
| 06540 | Amatom Electronic Hardware Co. Inc. | New Rochelle, N. Y. |
| 06555 | Beede Electrical Instrument Co. | Penacook, N. H. |
| 06666 | General Devices Co. Inc. | Indianapolis, Ind. |
| 06751 | Semcor Div. Components, Inc. | Phoenix, Arizona |
| 06776 | Robinson Nugent, Inc. | New Albany, Ind. |
| 06812 | Torrington Mfg. Co., West Div. | Van Nuys, Calif. |
| 07137 | Transistor Electronics Corp. | Minneapolis, Minn. |

| CODE NO. | MANUFACTURER | ADDRESS |
|----------|-----------------------------------------------------------------------------|--------------------------------------|
| 07138 | Westinghouse Electric Corp. Electronic Tube Div. | Elmira, N. Y. |
| 07263 | Fairchild Camera and Instrument Corp. Semiconductor Div. | Mountain View, Calif. |
| 07387 | Birtcher Corp., The | Los Angeles, Calif. |
| 07397 | Sylvania Electric Prod. Inc. Sylvania Electronic Systems Western Div. | Mountain View, Calif. |
| 07716 | IRC Div. of TRW Inc. | Burlington Plant Burlington, Iowa |
| 07910 | Continental Device Corp. | Hawthorne, Calif. |
| 07933 | Raytheon Co. Components Div. Semiconductor Operation | Mountain View, Calif. |
| 08484 | Breeze Corporations, Inc. | Union, N. J. |
| 08530 | Reliance Mica Corp. | Brooklyn, N. Y. |
| 08717 | Sloan Company, The | Sun Valley, Calif. |
| 08730 | Vemaline Products Co. Inc. | Wyckoff, N. J. |
| 08806 | General Elect. Co. Minia- ture Lamp Dept. | Cleveland, Ohio |
| 08863 | Nylomatic Corp. | Norrisville, Pa. |
| 08919 | RCH Supply Co. | Vernon, Calif. |
| 09021 | Airco Speer Electronic Components | Bradford, Pa. |
| 09182 | *Hewlett-Packard Co. New Jersey Div. | Berkeley Heights, N. J. |
| 09213 | General Elect. Co. Semiconductor Prod. Dept. | Buffalo, N. Y. |
| 09214 | General Elect. Co. Semiconductor Prod. Dept. | Auburn, N. Y. |
| 09353 | C & K Components Inc. | Newton, Mass. |
| 09922 | Burndy Corp. | Norwalk, Conn. |
| 11115 | Wagner Electric Corp. Tung-Sol Div. | Bloomfield, N. J. |
| 11236 | CTS of Berne, Inc. | Berne, Ind. |
| 11237 | Chicago Telephone of Cal. Inc. | So. Pasadena, Calif. |
| 11502 | IRC Div. of TRW Inc. | Boone Plant Boone, N. C. |
| 11711 | General Instrument Corp Rectifier Div. | Newark, N. J. |
| 12136 | Philadelphia Handle Co. Inc. | Camden, N. J. |
| 12615 | U. S. Terminals, Inc. | Cincinnati, Ohio |
| 12617 | Hamlin Inc. | Lake Mills, Wisconsin |
| 12697 | Clarostat Mfg. Co. Inc. | Dover, N. H. |
| 13103 | Thermalloy Co. | Dallas, Texas |
| 14493 | *Hewlett-Packard Co. Loveland Div. | Loveland, Colo. |
| 14655 | Cornell-Dubilier Electronics Div. Federal Pacific Electric Co. | Newark, N. J. |
| 14936 | General Instrument Corp. Semicon- ductor Prod. Group | Hicksville, N. Y. |
| 15801 | Fenwal Elect. | Framingham, Mass. |
| 16299 | Corning Glass Works, Electronic Components Div. | Raleigh, N. C. |

*Use Code 28480 assigned to Hewlett-Packard Co., Palo Alto, California

Table 6-3. Code List of Manufacturers (Continued)

| CODE NO. | MANUFACTURER | ADDRESS |
|----------|-----------------------------------------------------------------------------|----------------------------|
| 16758 | Delco Radio Div. of General Motors Corp. | Kokomo, Ind. |
| 17545 | Atlantic Semiconductors, Inc. | Asbury Park, N. J. |
| 17803 | Fairchild Camera and Instrument Corp Semiconductor Div. Transducer Plant | Mountain View, Calif. |
| 17870 | Daven Div. Thomas A. Edison Industries McGraw-Edison Co. | Orange, N. J. |
| 18324 | Signetics Corp. | Sunnyvale, Calif. |
| 19315 | Bendix Corp. The Navigation and Control Div. | Teterboro, N. J. |
| 19701 | Electra/Midland Corp. | Mineral Wells, Texas |
| 21520 | Fansteel Metallurgical Corp. | No. Chicago, Ill. |
| 22229 | Union Carbide Corp. Electronics Div. | Mountain View, Calif. |
| 22753 | UID Electronics Corp. | Hollywood, Fla. |
| 23936 | Pamotor, Inc. | Pampa, Texas |
| 24446 | General Electric Co. | Schenectady, N. Y. |
| 24455 | General Electric Co. Lamp Div. of Con- sumer Prod. Group | Nela Park, Cleveland, Ohio |
| 24655 | General Radio Co. | West Concord, Mass. |
| 24681 | LTV Electrosystems Inc Memcor/Com- ponents Operations | Huntington, Ind. |
| 26982 | Dynacool Mfg. Co. Inc. | Saugerties, N. Y. |
| 27014 | National Semiconductor Corp. | Santa Clara, Calif. |
| 28480 | Hewlett-Packard Co. | Palo Alto, Calif. |
| 28520 | Heyman Mfg. Co. | Kenilworth, N. J. |
| 28875 | IMC Magnetics Corp. | |
| | New Hampshire Div. | Rochester, N. H. |
| 31514 | SAE Advance Packaging, Inc. | Santa Ana, Calif. |
| 31827 | Budwig Mfg. Co. | Ramona, Calif. |
| 33173 | G. E. Co. Tube Dept. | Owensboro, Ky. |
| 35434 | Lectrohm, Inc. | Chicago, Ill. |
| 37942 | P. R. Mallory & Co. Inc. | Indianapolis, Ind. |
| 42190 | Muter Co. | Chicago, Ill. |
| 43334 | New Departure-Hyatt Bearings Div. | |
| | General Motors Corp. | Sandusky, Ohio |
| 44655 | Ohmite Manufacturing Co. | Skokie, Ill. |
| 46384 | Penn Engr. and Mfg. Corp. | Doylestown, Pa. |
| 47904 | Polaroid Corp. | Cambridge, Mass. |
| 49956 | Raytheon Co. | Lexington, Mass. |
| 55026 | Simpson Electric Co. Div. of American Gage and Machine Co. | Chicago, Ill. |
| 56289 | Sprague Electric Co. | North Adams, Mass. |
| 58474 | Superior Electric Co. | Bristol, Conn. |
| 58849 | Syntron Div. of FMC Corp. | Homer City, Pa. |
| 59730 | Thomas and Betts Co. | Philadelphia, Pa. |
| 61637 | Union Carbide Corp. | New York, N. Y. |
| 63743 | Ward Leonard Electric Co. | Mt. Vernon, N. Y. |

| CODE NO. | MANUFACTURER | ADDRESS |
|----------|-----------------------------------------------|-----------------------|
| 70563 | Amperite Co. Inc. | Union City, N. J. |
| 70901 | Beemer Engrg. Co. | Fort Washington, Pa. |
| 70903 | Belden Corp. | Chicago, Ill. |
| 71218 | Bud Radio, Inc. | Willoughby, Ohio |
| 71279 | Cambridge Thermionic Corp. | Cambridge, Mass. |
| 71400 | Bussmann Mfg. Div. of McGraw & Edison Co. | St. Louis, Mo. |
| 71450 | CTS Corp. | Elkhart, Ind. |
| 71468 | I. T. T. Cannon Electric Inc. | Los Angeles, Calif. |
| 71590 | Globe-Union Inc. | |
| | Centralab Div. | Milwaukee, Wis. |
| 71700 | General Cable Corp. Cornish Wire Co. Div. | Williamstown, Mass. |
| 71707 | Coto Coil Co. Inc. | Providence, R. I. |
| 71744 | Chicago Miniature Lamp Works | Chicago, Ill. |
| 71785 | Cinch Mfg. Co. and Howard B. Jones Div. | Chicago, Ill. |
| 71984 | Dow Corning Corp. | Midland, Mich. |
| 72136 | Electro Motive Mfg. Co. Inc. | Willimantic, Conn. |
| 72619 | Dialight Corp. | Brooklyn, N. Y. |
| 72699 | General Instrument Corp. | Newark, N. J. |
| 72765 | Drake Mfg. Co. | Harwood Heights, Ill. |
| 72962 | Elastic Stop Nut Div. of Amerex Esna Corp. | Union, N. J. |
| 72982 | Erie Technological Products Inc. | Erie, Pa. |
| 73096 | Hart Mfg. Co. | Hartford, Conn. |
| 73138 | Beckman Instruments Inc. | |
| | Helipot Div. | Fullerton, Calif. |
| 73168 | Fenwal, Inc. | Ashland, Mass. |
| 73293 | Hughes Aircraft Co. Electron Dynamics Div. | Torrance, Calif. |
| 73445 | Amperex Electronic Corp. | Hicksville, N. Y. |
| 73506 | Bradley Semiconductor Corp. | New Haven, Conn. |
| 73559 | Carling Electric, Inc. | Hartford, Conn. |
| 73734 | Federal Screw Products, Inc. | Chicago, Ill. |
| 74193 | Heinemann Electric Co. | Trenton, N. J. |
| 74545 | Hubbell Harvey Inc. | Bridgeport, Conn. |
| 74868 | Amphenol Corp. Amphenol RF Div. | Danbury, Conn. |
| 74970 | E. F. Johnson Co. | Waseca, Minn. |
| 75042 | IRC Div. of TRW, Inc. | Philadelphia, Pa. |
| 75183 | *Howard B. Jones Div. of Cinch Mfg. Corp. | New York, N. Y. |
| 75376 | Kurz and Kasch, Inc. | Dayton, Ohio |
| 75382 | Kilka Electric Corp. | Mt. Vernon, N. Y. |
| 75915 | Littlefuse, Inc. | Des Plaines, Ill. |
| 76381 | Minnesota Mining and Mfg. Co. | St. Paul, Minn. |
| 76385 | Minor Rubber Co. Inc. | Bloomfield, N. J. |
| 76487 | James Millen Mfg. Co. Inc. | Malden, Mass. |
| 76493 | J. W. Miller Co. | Compton, Calif. |

*Use Code 71785 assigned to Cinch Mfg. Co., Chicago, Ill.

Table 6-3. Code List of Manufacturers (Continued)

| CODE NO. | MANUFACTURER | ADDRESS |
|----------|------------------------------------------|--------------------------|
| 76530 | Cinch | City of Industry, Calif. |
| 76854 | Oak Mfg. Co. Div. of Oak | |
| | Electro/Netics Corp. | Crystal Lake, Ill. |
| 77068 | Bendix Corp., Electrodynamics Div. | No. Hollywood, Calif. |
| 77122 | Palnut Co. | Mountainside, N. J. |
| 77147 | Patton-MacGuyer Co. | Providence, R. I. |
| 77221 | Phaostron Instrument and Electronic Co. | South Pasadena, Calif. |
| 77252 | Philadelphia Steel and Wire Corp. | Philadelphia, Pa. |
| 77342 | American Machine and Foundry Co. | |
| | Potter and Brumfield Div. | Princeton, Ind. |
| 77630 | TRW Electronic Components Div. | Camden, N. J. |
| 77764 | Resistance Products Co. | Harrisburg, Pa. |
| 78189 | Illinois Tool Works Inc. Shakeproof Div. | Elgin, Ill. |
| 78452 | Everlock Chicago, Inc. | Chicago, Ill. |
| 78488 | Stackpole Carbon Co. | St. Marys, Pa. |
| 78526 | Stanwyck Winding Div. | San Fernando |
| | Electric Mfg. Co. Inc. | Newburgh, N. Y. |
| 78553 | Tinnerman Products, Inc. | Cleveland, Ohio |
| 78584 | Stewart Stamping Corp. | Yonkers, N. Y. |
| 79136 | Waldes Kohinoor, Inc. | L. I. C., N. Y. |
| 79307 | Whitehead Metals Inc. | New York, N. Y. |
| 79727 | Continental-Wirt Electronics Corp. | Philadelphia, Pa. |
| 79963 | Zierick Mfg. Co. | Mt. Kisco, N. Y. |
| 80031 | Mepco Div. of Sessions Clock Co. | Morristown, N. J. |
| 80294 | Bourns, Inc. | Riverside, Calif. |
| 81042 | Howard Industries Div. of Msl Ind. Inc. | Racine, Wisc. |
| | | La Grange, Ill. |
| 81073 | Grayhill, Inc. | |
| 81483 | International Rectifier Corp. | El Segundo, Calif. |
| 81751 | Columbus Electronics Corp. | Yonkers, N. Y. |
| 82099 | Goodyear Sundries & Mechanical Co. Inc. | New York, N. Y. |
| 82142 | Airco Speer Electronic Components | Du Bois, Pa. |
| 82219 | Sylvania Electric Products Inc. | |
| | Electronic Tube Div. Receiving | |
| | Tube Operations | Emporium, Pa. |
| 82389 | Switchcraft, Inc. | Chicago, Ill. |
| 82647 | Metals and Controls Inc. Control | |
| | Products Group | Attleboro, Mass. |
| 82866 | Research Products Corp. | Madison, Wis. |
| 82877 | Rotron Inc. | Woodstock, N. Y. |
| 82893 | Vector Electronic Co. | Glendale, Calif. |
| 83058 | Carr Fastener Co. | Cambridge, Mass. |
| 83186 | Victory Engineering Corp. | Springfield, N. J. |
| 83298 | Bendix Corp. Electric Power Div. | Eatontown, N. J. |
| 83330 | Herman H. Smith, Inc. | Brooklyn, N. Y. |
| 83385 | Central Screw Co. | Chicago, Ill. |
| 83501 | Gavitt Wire and Cable Div. of | |
| | Amerace Esna Corp. | Brookfield, Mass. |

| CODE NO. | MANUFACTURER | ADDRESS |
|----------|-----------------------------------------|-----------------------|
| 83508 | Grant Pulley and Hardware Co. | West Nyack, N. Y. |
| 83594 | Burroughs Corp. Electronic | |
| | Components Div. | Plainfield, N. J. |
| 83835 | U. S. Radium Corp. | Morristown, N. J. |
| 83877 | Yardeny Laboratories, Inc. | New York, N. Y. |
| 84171 | Arco Electronics, Inc. | Great Neck, N. Y. |
| 84411 | TRW Capacitor Div. | Ogallala, Neb. |
| 86684 | RCA Corp. Electronic Components | Harrison, N. J. |
| | | Newark, N. J. |
| 86838 | Rummel Fibre Co. | |
| 87034 | Marco & Oak Industries a Div. of Oak | |
| | Electro/netics Corp. | Anaheim, Calif. |
| 87216 | Philco Corp. Lansdale Div. | Lansdale, Pa. |
| 87585 | Stockwell Rubber Co. Inc. | Philadelphia, Pa. |
| 87929 | Tower-Olschan Corp. | Bridgeport, Conn. |
| 88140 | Cutler-Hammer Inc. Power Distribution | |
| | and Control Div. Lincoln Plant | Lincoln, Ill. |
| 88245 | Litton Precision Products Inc, USECO | |
| | Div. Litton Industries | Van Nuys, Calif. |
| 90634 | Gulton Industries Inc. | Metuchen, N. J. |
| 90763 | United-Car Inc. | Chicago, Ill. |
| 91345 | Miller Dial and Nameplate Co. | El Monte, Calif. |
| 91418 | Radio Materials Co. | Chicago, Ill. |
| 91506 | Augat, Inc. | Attleboro, Mass. |
| 91637 | Dale Electronics, Inc. | Columbus, Neb. |
| 91662 | Elco Corp. | Willow Grove, Pa. |
| 91929 | Honeywell Inc. Div. Micro Switch | Freeport, Ill. |
| 92825 | Whitso, Inc. | Schiller Pk., Ill. |
| 93332 | Sylvania Electric Prod. Inc. Semi- | |
| | conductor Prod. Div. | Woburn, Mass. |
| 93410 | Essex Wire Corp. Stemco | |
| | Controls Div. | Mansfield, Ohio |
| 94144 | Raytheon Co. Components Div. | |
| | Ind. Components Oper. | Quincy, Mass. |
| 94154 | Wagner Electric Corp. | |
| | Tung-Sol Div. | Livingston, N. J. |
| 94222 | Southco Inc. | Lester, Pa. |
| 95263 | Leecraft Mfg. Co. Inc. | L. I. C., N. Y. |
| 95354 | Methode Mfg. Co. | Rolling Meadows, Ill. |
| 95712 | Bendix Corp. Microwave | |
| | Devices Div. | Franklin, Ind. |
| 95987 | Weckesser Co. Inc. | Chicago, Ill. |
| 96791 | Amphenol Corp. Amphenol | |
| | Controls Div. | Janesville, Wis. |
| 97464 | Industrial Retaining Ring Co. | Irvington, N. J. |
| 97702 | IMC Magnetics Corp. Eastern Div. | Westbury, N. Y. |
| 98291 | Sealectro Corp. | Mamaroneck, N. Y. |
| 98410 | ETC Inc. | Cleveland, Ohio |
| 98978 | International Electronic Research Corp. | Burbank, Calif. |
| 99934 | Renbrandt, Inc. | Boston, Mass. |

Table 6-4. Replaceable Parts

| REF. DESIG. | DESCRIPTION | TQ | MFR. PART NO. | MFR. CODE | HP PART NO. | RS |
|---------------|---------------------------------|----|----------------|-----------|-------------|----|
| A1 | POWER SUPPLY BOARD | | | | | |
| C1-C3 | fxd, elect. 490 μ F 85Vdc | 3 | | 28480 | 0180-1888 | 1 |
| C4 | | 1 | | | | 1 |
| 6104A & 6114A | fxd, elect. 4000 μ F 45Vdc | | 32D5773 | 56289 | 0180-2547 | |
| 6105A & 6115A | fxd, elect. 1600 μ F 85Vdc | | 32D5279 | 56289 | 0180-1986 | |
| C5-C7 | fxd, cer .05 μ F 400Vdc | 6 | 33C17A3 | 56289 | 0150-0052 | 2 |
| C8 | | 1 | | | | 1 |
| 6104A & 6114A | fxd, elect. 4000 μ F 45 Vdc | | 32D5773 | 56289 | 0180-2547 | |
| 6105A & 6115A | fxd, elect. 1600 μ F 85Vdc | | 32D5279 | 56289 | 0180-1986 | |
| C9 | fxd, cer .05 μ F 400Vdc | | 33C17A3 | 56289 | 0150-0052 | |
| C10 | fxd, elect. 22 μ F 35Vdc | 1 | 150D226X0035R2 | 56289 | 0180-0160 | 1 |
| C11 | Not Assigned | — | — | — | — | — |
| C12 | | 1 | | | | 1 |
| 6104A & 6114A | fxd, elect. 490 μ F 85Vdc | | | 28480 | 0180-1888 | |
| 6105A & 6115A | fxd, elect. 200 μ F 150Vdc | | | 28480 | 0180-1885 | |
| C13 | fxd, mica 510pF 500Vdc | 1 | RCM15E511J | 00853 | 0140-0047 | 1 |
| C14 | fxd, tant.1 μ F 35Vdc | 1 | 150D105X9035A2 | 56289 | 0180-0291 | 1 |
| C15,16 | fxd, cer .05 μ F 400Vdc | | 33C17A3 | 56289 | 0150-0052 | |
| CR1-6 | Diode, Si 200prv | 7 | 1N5095 | 28480 | 1901-0327 | 6 |
| CR7-12 | Diode, Si 200prv | 9 | 1N4999 | 28480 | 1901-0416 | 6 |
| CR13 | Diode, Si 200prv | | 1N5095 | 28480 | 1901-0327 | |
| CR14 | Stabistor, Si 10prv | 3 | STB 523 | 09213 | 1901-0460 | 3 |
| CR15-17 | Diode, Si 200prv | | 1N4999 | 28480 | 1901-0416 | |
| CR18 | Diode, Si 200prv | 3 | D6238 | 93332 | 1901-0033 | 3 |
| CR19 | Not Assigned | — | — | — | — | — |
| CR20 | SCR, 600V 2A | 1 | 2N4102 | 28480 | 1884-0044 | 1 |
| CR21, 22 | Diode, Si 200prv | | D6238 | 93332 | 1901-0033 | |
| CR23, 24 | Stabistor, Si 10prv | | STB 523 | 09213 | 1901-0460 | |
| J1 | Connector, 15 pin | 1 | 143-015-07 | 96791 | 1251-0213 | 1 |
| Q1 | SS NPN Si | 1 | 2N4141* | 28480 | 1854-0071 | 1 |
| L1 | Coil 2.3 μ H | 1 | | 28480 | 9140-0121 | 1 |
| R1,2 | | 2 | | | | 1 |
| 6104A & 6114A | fxd, ww 1K \pm 5% 5W | | 243E-1025 | 56289 | 0812-0099 | |
| 6105A & 6115A | fxd, ww 3K \pm 5% 5W | | 243E-3025 | 56289 | 0812-0050 | |
| R3 | | 2 | | | | 1 |
| 6104A & 6114A | fxd, ww 600 \pm 5% 10W | | 247E-6015 | 56289 | 0811-1910 | |
| 6105A & 6115A | fxd, ww 1K \pm 5% 10W | | 247E-1025 | 56289 | 0811-1586 | |
| R4 | Not Assigned | — | — | — | — | — |
| R5,6 | | 2 | | | | 1 |
| 6104A & 6114A | fxd, ww 2 \pm 5% 5W | | RS5-78 | 91637 | 0811-1850 | |
| 6105A & 6115A | fxd, ww 5 \pm 5% 5W | | 243E | 56289 | 0812-0047 | |
| R7 | var, ww 10 \pm 20% 1.5W | 1 | 110-F4 | 11236 | 2100-1822 | 1 |
| R8 | | 1 | | | | 1 |
| 6104A & 6114A | fxd, comp 560 \pm 5% 1/2W | | EB5615 | 01121 | 0686-5615 | |
| 6105A & 6115A | fxd, comp 2K \pm 5% 1/2W | | EB2025 | 01121 | 0686-2025 | |
| R9,10 | | 1 | | | | 1 |
| 6104A & 6114A | fxd, ww 1 \pm 5% 3W | | 242E1R05 | 56289 | 0811-1732 | |
| 6105A & 6115A | fxd, ww 2 \pm 5% 3W | | 242E2R05 | 56289 | 0811-1831 | |
| R11 | | 1 | | | | 1 |
| 6104A & 6114A | fxd, comp 560 \pm 5% 1/2W | | EB5615 | 01121 | 0686-5615 | |
| 6105A & 6115A | fxd, comp 1K \pm 5% 1/2W | | EB1025 | 01121 | 0686-1025 | |
| R12 | fxd, comp 11K \pm 5% 1/2W | 1 | EB1135 | 01121 | 0686-1135 | 1 |

* Not exact replacement, but a suitable alternate in most cases.

Table 6-4. Replaceable Parts (continued)

| REF. DESIG. | DESCRIPTION | TQ | MFR. PART NO. | MFR. CODE | HP PART NO. | RS |
|---------------|-------------------------------|----|---------------|-----------|-------------|----|
| R13 | fxd, comp 1K \pm 5% 1/2W | 1 | EB1025 | 01121 | 0686-1025 | 1 |
| R14 | | 1 | | | | 1 |
| 6104A & 6114A | fxd, comp 10 \pm 5% 1/2W | | EB1005 | 01121 | 0686-1005 | |
| 6105A & 6115A | fxd, comp 27 \pm 5% 1/2W | | EB2705 | 01121 | 0686-2705 | |
| R15 | | 1 | | | | 1 |
| 6104A & 6114A | fxd, ww 0.5 \pm 1% 8W | | Type T-7A | 01686 | 0811-2103 | |
| 6105A & 6115A | fxd, ww 1 \pm .5% 8W | | Type T-7A | 01686 | 0811-2133 | |
| R16 | | 1 | | | | 1 |
| 6104A & 6114A | fxd, film 1K \pm 1% 1/8W | | Type CEA T-0 | 07716 | 0757-0280 | |
| 6105A & 6115A | fxd, film 825 \pm 1% 1/8W | | Type CEA T-0 | 07716 | 0757-0421 | |
| R17 | Not Used | | | | | |
| R18 | | 1 | | | | 1 |
| 6104A & 6114A | fxd, film 11.8 \pm 1% 1/8W | | Type CEA T-0 | 07716 | 0698-4354 | |
| 6105A & 6115A | fxd, film 10 \pm 1% 1/8W | | Type CEA T-0 | 07716 | 0757-0346 | |
| R19 | | 1 | | | | 1 |
| 6104A & 6114A | fxd, film 196 \pm 1% 1/8W | | Type CEA T-0 | 07716 | 0698-3440 | |
| 6105A & 6115A | fxd, film 90.9 \pm 1% 1/8W | | Type CEA T-0 | 07716 | 0757-0400 | |
| R20 | | 1 | | | | 1 |
| 6104A & 6114A | fxd, film 47.5K \pm 1% 1/8W | | Type CEA T-0 | 07716 | 0757-0457 | |
| 6105A & 6115A | fxd, film 118K \pm 1% 1/8W | | Type CEA T-0 | 07716 | 0698-3265 | |
| R21 | fxd, film 1M \pm 1% 1/4W | 1 | Type CCA T-0 | 07716 | 0757-0344 | 1 |
| R22 | var, ww 5K \pm 20% 1.5W | 1 | Type 110-F4 | 11236 | 2100-1824 | 1 |
| R23, R24 | Not Assigned | - | - | - | - | - |
| R25 | fxd, ww 0.25 \pm 10% 3W | 1 | Type CW2B-1 | 91637 | 0811-1829 | 1 |
| R26 | Not Assigned | - | - | - | - | - |
| R27 | fxd, comp 47 \pm 5% 1/2W | 1 | EB4705 | 01121 | 0686-4705 | 1 |
| R28 | fxd, comp 1.5K \pm 5% 1/2W | 1 | EB1525 | 01121 | 0686-1525 | 1 |
| R29 | | 1 | | | | 1 |
| 6104A & 6114A | fxd, film 40K \pm 1% 1/8W | | Type CEA T-0 | 07716 | 0698-7421 | |
| 6105A & 6115A | fxd, film 31.6K \pm 1% 1/8W | | Type CEA T-0 | 07716 | 0698-3160 | |
| R30 | | 1 | | | | 1 |
| 6104A & 6114A | fxd, film 261K \pm 1% 1/8W | | Type CEA T-0 | 07716 | 0698-3455 | |
| 6105A & 6115A | fxd, film 562K \pm 1% 1/8W | | Type CEA T-0 | 07716 | 0757-0483 | |
| R31 | fxd, ww 1.3K \pm 5% 3W | 1 | 242E 1325 | 56289 | 0811-1803 | 1 |
| R32 | Not Assigned | - | - | - | - | - |
| R33 | | 1 | | | | 1 |
| 6104A & 6114A | fxd, comp 1.3K \pm 5% 1/2W | | EB1325 | 01121 | 0686-1325 | |
| 6105A & 6115A | fxd, comp 2K \pm 5% 1/2W | | EB2025 | 01121 | 0686-2025 | |
| R34 | fxd, ww 1 \pm 5% 3W | 1 | 242E1R05 | 56289 | 0811-1732 | 1 |
| R35-R37 | Not Assigned | - | - | - | - | - |
| R38 | | 1 | | | | 1 |
| 6104A & 6114A | fxd, film 221K \pm 1% 1/8W | | Type CEA T-0 | 07716 | 0757-0473 | |
| 6105A & 6115A | Not Used | - | - | - | - | - |
| R39 | | 1 | | | | 1 |
| 6104A & 6114A | Not Used | - | - | - | - | - |
| 6105A & 6115A | fxd, film 6.49K \pm 1% 1/8W | | Type CEA T-0 | 07716 | 0698-3226 | |
| R40 | | 1 | | | | 1 |
| 6104A & 6114A | fxd, comp 1.3K \pm 5% 1/2W | | EB1325 | 01121 | 0686-1325 | |
| 6105A & 6115A | fxd, comp 2K \pm 5% 1/2W | | EB2025 | 01121 | 0686-2025 | |
| R41 | | 1 | | | | 1 |
| 6104A & 6114A | fxd, ww 10K \pm 1% 5W | | 243E-1035 | 56289 | 0811-1866 | |
| 6105A & 6115A | fxd, ww 15K \pm 5% 5W | | 243E-1535 | 56289 | 0811-1867 | |
| T1 | Transformer, crowbar | 1 | | 28480 | 5080-7188 | 1 |
| U1 | Voltage Comparator, IC | 1 | LM311H | 27014 | 1826-0026 | 1 |

Table 6-4. Replaceable Parts (continued)

| REF. DESIG. | DESCRIPTION | TQ | MFR. PART NO. | MFR. CODE | HP PART NO. | RS |
|--------------------------------------------------|-------------------------------------------------------------------------------|------------|-------------------------------|-------------------------|-------------------------------------|------------|
| VR2,3,5 6104A & 6114A 6105A & 6115A VR4 | Diode, zener 4.32V 1W Diode, zener 4.22V 400mW Diode, zener 2.37V 400mW | 3 1 | 1N5221B 1N5229B 1N4731A | 28480 28480 28480 | 1902-0797 1902-3070 1902-3002 | 3 1 |
| A2 | CONTROL BOARD | | | | | |
| C1 | fxd, mica 82pF 500Vdc | 1 | | 28480 | 0140-0048 | 1 |
| C2 | fxd, elect. 22 μ F 35Vdc | 1 | 150D226X0035R2 | 56289 | 0180-0160 | 1 |
| C3 | Not Assigned | — | | | | — |
| C4 | fxd, mylar .0022 μ F 200Vdc | 2 | 192P22292 | 56289 | 0160-0154 | 1 |
| C5 | Not Assigned | — | | | | — |
| C6 | fxd, mylar .0022 μ F 200Vdc | | 192P22292 | 56289 | 0160-0154 | |
| C7 | fxd, tant. 1 μ F 35Vdc | 1 | 150D105X9035A2 | 56289 | 0180-0291 | 1 |
| CR1 | Stabistor, Si 10prv | 2 | STB 523 | 09213 | 1901-0460 | 1 |
| CR2,3 | Diode, Si 250mA 75V | 2 | FDH 6308 | 07263 | 1901-0050 | 1 |
| CR4-CR6 | Diode, Si 250mW 200V | 3 | SG 3396 | 12065 | 1901-0033 | 1 |
| CR7 | Stabistor, Si 10prv | | STB 523 | 09213 | 1901-0460 | |
| Q1 | SS NPN Si | 1 | 2N1711A/2N2102A | 28480 | 1854-0244 | 1 |
| Q2 | SS PNP Si | 3 | 2N2907/2N3906 | 28480 | 1853-0099 | 3 |
| Q3 * | SS NPN Si | 1 | 2N3417* | 28480 | 1854-0087 | 1 |
| Q4,5 | SS PNP Si | | 2N2907/2N3906 | 28480 | 1853-0095 | |
| R1 | fxd, ww 1K \pm 5% 3W | 1 | 242E-1025 | 56289 | 0813-0001 | 1 |
| R2 | fxd, 1K \pm 5% 1/2W | 1 | EB1025 | 01121 | 0686-1025 | 1 |
| R3** | fxd, ww 408.2 \pm .1% 1/8W | 1 | Type 7007 | 01686 | 0811-2762 | 1 |
| R4 | fxd, film 121 \pm 1% 1/4W | 1 | Type CCA T-0 | 07716 | 0757-0069 | 1 |
| R5 | var, film 1K \pm 10% 1/2W | 1 | | 28480 | 2100-3256 | 1 |
| R6 | fxd, film 6.19K \pm 1% 1/8W | 1 | Type CEA T-0 | 07716 | 0757-0290 | 1 |
| R7 | fxd, film 10K \pm 1% 1/8W | 1 | Type CEA T-0 | 07716 | 0757-0442 | 1 |
| R8A & B | fxd, ww 10.00K & 15.82K \pm 0.1% 1/8W (Matched Pair) | 1 | | 21480 | 0811-2572 | 1 |
| R9 | fxd, film 1.3K \pm 1% 1/8W | 1 | Type CEA T-0 | 07716 | 0698-6337 | 1 |
| R10 | fxd, comp 2.2K \pm 5% 1/2W | 1 | EB2225 | 01121 | 0686-2225 | 1 |
| R11 | fxd, film 1K \pm 1% 1/8W | 1 | Type CEA T-0 | 07716 | 0757-0280 | 1 |
| R12,13 | var, ww 10K \pm 5% 1W | 2 | | 28480 | 2100-0989 | 1 |
| R14 | fxd, comp 22K \pm 5% 1/2W | 1 | EB2235 | 01121 | 0686-2225 | 1 |
| R15 | fxd, ww 2K \pm 5% 3W | 1 | 242E-2025 | 56289 | 0811-1806 | 1 |
| R16 | fxd, film 560 \pm 1% 1/4W | 1 | Type CEB T-0 | 07716 | 0698-5146 | 1 |
| R17 | var, ww 250 \pm 20% 1.5W | 1 | Type 110-F4 | 11236 | 2100-0439 | 1 |
| R18 | fxd, film 10K \pm 1% 1/8W | | Type CEA T-0 | 07716 | 0757-0442 | |
| R19 | var, ww 1K \pm 5% 1W | 1 | Type CT-106-4 | 07716 | 2100-1758 | 1 |
| R20 | fxd, ww 5.5K \pm 1% 1/4W | 1 | | 28480 | 0811-1957 | 1 |
| R21 | fxd, film 1.5K \pm 1% 1/8W | 1 | Type CEA T-0 | 07716 | 0757-0427 | 1 |
| R22 | Not Assigned | — | | | | — |
| R23 | fxd, film 562K \pm 1% 1/8W | 1 | Type CEA T-0 | 07716 | 0757-0483 | 1 |
| R24 | fxd, ww 32K \pm .05% 1/4W | 1 | | 28480 | 0811-3178 | 1 |
| R25 | fxd, ww 490 \pm 5% 3W | 1 | 242E-4915 | 56289 | 0811-1801 | 1 |
| R26 | fxd, film 909 \pm 1% 1/8W | 1 | Type CEA T-0 | 07716 | 0757-0422 | 1 |
| R27 | fxd, ww 1.3K \pm 5% 3W | 1 | 242E-1325 | 56289 | 0811-1803 | 1 |
| U1-U3 | Operational Amplifier, IC | 3 | ULS 2151D | 56289 | 1826-0090 | 3 |
| VR1 | Diode, zener 6.2V 250mW | 1 | 1N829 | 28480 | 1902-0625 | 1 |
| VR2 | Diode, zener 6.2V 250mW | 2 | 1N825 | 28480 | 1902-1221 | 2 |
| VR3 | Diode, zener 14.7V 400mW | 1 | CD3754 | 07910 | 1902-3203 | 1 |
| VR4 | Diode, zener 6.2V 250mW | | 1N825 | 28480 | 1902-1221 | |

** R3 is either a jumper or 408.2 Ω depending on results of calibration. Refer to Section V.

* Not exact replacement, but a suitable alternate in most cases.

Table 6-4. Replaceable Parts (continued)

| REF. DESIG. | DESCRIPTION | TQ | MFR. PART NO. | MFR. CODE | HP PART NO. | RS |
|---------------|------------------------------------------------------------|----|----------------|-----------|-------------|----|
| C3 | FRONT PANEL-ELECTRICAL | | | | | |
| 6104A & 6114A | fxd, elect. 15 μ F 50Vdc | 1 | 150D156X0050R2 | 56289 | 0180-1834 | 1 |
| 6105A & 6115A | fxd, elect. 5 μ F 150Vdc | | 40D505F150DC4 | 56289 | 0180-1841 | |
| DS1 | Indicator Lamp, Neon (LINE) | 1 | A1C | 08806 | 2140-0047 | 1 |
| DS2,3 | Indicator, Light Emitting Diode (MODE/OVERVOLTAGE) | 2 | | 28480 | 1990-0325 | 1 |
| E1,2 | 5-Way Binding Post, Red | 2 | | 28480 | 1510-0074 | |
| E3 | 5-Way Binding Post, Black | 1 | | 28480 | 1510-0075 | |
| M1 | | 1 | | | | 1 |
| 6104A | Meter, 0-2.4A | | | 28480 | 1120-1368 | |
| 6105A | Meter, 0-1A | | | 28480 | 1120-1376 | |
| 6114A | Meter, Dual 0-2.4A/0-50V | | | 28480 | 1120-1366 | |
| 6115A | Meter, Dual 0-1A/0-120V | | | 28480 | 1120-1374 | |
| M2 | | 1 | | | | 1 |
| 6104A | Meter, 0-50V | | | 28480 | 1120-1377 | |
| 6105A | Meter, 0-120V | | | 28480 | 1120-1375 | |
| 6114A & 6115A | Not Used | - | - | - | - | - |
| R1 | fxd, comp 47K \pm 5% 1/2W | 1 | EB4735 | 01121 | 0686-4735 | 1 |
| R2 | var, ww 1K \pm 5% 2W (CURRENT Control) | 1 | | 28480 | 2100-3281 | 1 |
| R3 | var, comp 5K \pm 20% 1/2W | 1 | | 28480 | 2100-0011 | 1 |
| R4 | (VOLTAGE Control) | 1 | | | | 1 |
| 6104A | var, ww 10T 100K \pm 5% 2W | | | 28480 | 2100-1869 | |
| 6105A | var, ww 10T 200K \pm 5% 2W | | | 28480 | 2100-3264 | |
| 6114A & 6115A | Not Used | - | - | - | - | - |
| S1 | Switch, Toggle SPDT 5A (LINE Switch) | 1 | | 28480 | 3101-1605 | 1 |
| S2 | (METER Switch) | 1 | | | | 1 |
| 6114A & 6115A | Switch, Slide 3PDT 3A | | SW-332 | 22753 | 3101-1288 | |
| 6104A & 6105A | Not Used | - | - | - | - | - |
| S3 | (VOLTAGE Control) | 1 | | | | 1 |
| 6104A & 6105A | Not Used | - | - | - | - | - |
| 6114A & 6115A | Programming Switch Assembly (includes resistance board A3) | | | 28480 | 06114-60001 | |
| A3 | Resistance Board | | | | | |
| R1 | fxd, ww 20 \pm .1% 1/4W | 1 | Type 143 | 20940 | 0811-3183 | 1 |
| R2-5 | fxd, ww 40 \pm .1% 1/4W | 4 | Type 143 | 20940 | 0811-3184 | 1 |
| R6 | fxd, ww 200 \pm .025% 1/16W | 1 | Type 143 | 20940 | 0811-3182 | 1 |
| R7-10 | fxd, ww 400 \pm .025% 1/16W | 4 | Type 143 | 20940 | 0811-3189 | 1 |
| R11 | fxd, ww 2K \pm .01% 1/16W | 1 | Type 143 | 20940 | 0811-3185 | 1 |
| R12-15 | fxd, ww 4K \pm .01% 1/16W | 4 | Type 143 | 20940 | 0811-3181 | 1 |
| R16 | fxd, ww 20K \pm .01% 1/16W | 1 | Type 143 | 20940 | 0811-3180 | 1 |
| R17-19 | | 3 | | | | 1 |
| 6115A | fxd, ww 40K \pm .01% 1/16W | | Type 143 | 20940 | 0811-3179 | |
| 6114A | wire jumpers | -- | --- | --- | --- | |
| R20 | fxd, ww 40K \pm .01% 1/16W | 1 | Type 143 | 20940 | 0811-3179 | 1 |
| R21 | var, ww 20 \pm 5% | 1 | | 28480 | 3100-3089 | 1 |

Table 6-4. Replaceable Parts (continued)

| REF. DESIG. | DESCRIPTION | TQ | MFR. PART NO. | MFR. CODE | HP PART NO. | RS |
|---------------|---------------------------------------------------------------------------|----|---------------|-----------|-------------|----|
| A4 | HEAT SINK ASSEMBLY-ELECTRICAL Heat Sink Board | | | | | |
| Q1-3 | | 3 | | | | 3 |
| 6104A & 6114A | Power NPN Si | | 2N6254 | | 1854-0563 | |
| 6105A & 6115A | Power NPN Si | | 2N3442* | | 1854-0250 | |
| Q4 | | 1 | | | | 1 |
| 6104A & 6114A | Power PNP Si | | 2N5954 | | 1853-0277 | |
| 6105A & 6115A | Power PNP Si | | 2N6211 | | 1853-0328 | |
| A5 | Interconnect Board | | | | | |
| C2 | fxd, elect. 3 μ F 100V | 1 | HEW249 | 84411 | 0160-3993 | 1 |
| R17 | fxd, comp 10 \pm 5% 1/2W | 1 | EB1005 | 01121 | 0686-1005 | 1 |
| A6 | Power Module (includes fuse and selector switch) | 1 | | 28480 | 5060-1189 | |
| F1 | Fuse, Cartridge 2A 250V 3AG | 1 | 312.002 | 75915 | 2110-0002 | 1 |
| TB1, 2 | Terminal Block | 2 | | 28480 | 0360-1766 | |
| C1 | CHASSIS-ELECTRICAL fxd, mylar 1 μ F 220Vac (connected across T1) | 1 | 439P1059220 | 56289 | 0160-3679 | 1 |
| T1 | Transformer, power | 1 | | 21480 | 5080-7189 | 1 |
| | A1 POWER SUPPLY BOARD-MECHANICAL Bushing Insulator (CR7-12, 15-17, 20) | 10 | | 28480 | 0340-0166 | |
| | HEAT SINK ASSEMBLY-MECHANICAL Bushing, Insulator (Q1-Q3) | 3 | | 28480 | 0340-0795 | |
| | Bushing, Insulator (Q4 screws) | 2 | | 28480 | 0340-0170 | |
| | Bushing, Insulator (Q4 pins) | 1 | | 28480 | 0340-0415 | |
| | Heat Sink | 1 | | 28480 | 5020-8085 | |
| | Insulator, Mica (Q1-Q3) | 3 | | 28480 | 0340-0181 | |
| | Insulator, Mica (Q4) | 1 | | 28480 | 0340-0180 | |
| | Rear Panel, upper | 1 | | 28480 | 5000-9346 | |
| | Rear Panel, lower | 1 | | 28480 | 5000-9345 | |
| | FRONT PANEL-MECHANICAL Bezel, Meter | | | | | |
| | 6104A & 6105A | 2 | | 28480 | 4040-0937 | |
| | 6114A & 6115A | 1 | | 28480 | 4040-0937 | |
| | Bushing (OVERVOLTAGE pot.) | 1 | | 28480 | 1410-0052 | |
| | Control Panel, upper | 1 | | | | |
| | 6104A | | | 28480 | 06104-60001 | |
| | 6105A | | | 28480 | 06105-60001 | |
| | 6114A | | | 28480 | 06114-60002 | |
| | 6115A | | | 28480 | 06115-60002 | |
| | Control Panel, lower | 1 | | 28480 | 5000-9347 | |
| | Collar, LED | 2 | | 28480 | 1400-0825 | |

* Not exact replacement, but a suitable alternate in most cases.

Table 6-4. Replaceable Parts (continued)

| REF. DESIG. | DESCRIPTION | TQ | MFR. PART NO. | MFR. CODE | HP PART NO. | RS |
|-------------|-----------------------------------------------|----|---------------|-----------|-------------|----|
| | Foot Assembly, Front | 1 | | 28480 | 5060-0728 | |
| | Insulator, Binding Post (Red) | 4 | | 28480 | 0340-0734 | |
| | Insulator, Binding Post (Black) | 1 | | 28480 | 0340-0733 | |
| | Knob (CURRENT pot.) | 1 | | 28480 | 0370-1099 | |
| | Knob (VOLTAGE pot.) | 1 | | | | |
| | 6104A & 6105A | | | 28480 | 0370-1091 | |
| | 6114A & 6115A: Not Used | | | | | |
| | Lamp Holder, Clear (LINE) | 1 | | 28480 | 5040-0234 | |
| | Lamp Holder, Black (LINE) | 1 | | 28480 | 5040-0305 | |
| | Panel, Voltage Control | | | | | |
| | 6114A & 6115A | 1 | | 28480 | 5000-9343 | |
| | 6104A & 6105A: Not Used | | | | | |
| | Trim, Meter | 1 | | 28480 | 5020-8061 | |
| | CHASSIS-MECHANICAL | | | | | |
| | Binding Post (GRD lug) | 1 | | 28480 | 1510-0044 | |
| | Chassis, Center | 1 | | 28480 | 5000-9344 | |
| | Chassis, Side (Left & Right) | 2 | | 28480 | 5060-0703 | |
| | Cover, Barrier Strip | 1 | | 28480 | 5000-9356 | |
| | Cover, Bottom | 1 | | 28480 | 5000-9366 | |
| | Cover, Side | 2 | | 28480 | 5000-8565 | |
| | Cover, Top | 1 | | 28480 | 5000-9367 | |
| | Foot Assembly, Rear | 1 | | 28480 | 5060-0728 | |
| | Jumper, Barrier Strip (3-section) | 3 | | 28480 | 0360-1784 | |
| | Jumper, Barrier Strip (2-section) | 1 | | 28480 | 0360-1785 | |
| | Standoff 8-32 X.375 (A1 Card) | 6 | | 28480 | 0380-0718 | |
| | Standoff 8-32 X .875 (A2 Card) | 2 | | 28480 | 0380-0849 | |
| | Standoff 6-32 X 1.00 (TB Cover) | 2 | | 28480 | 0380-0341 | |
| | MISCELLANEOUS | | | | | |
| | Fuse, Cartridge, 1A 250V 3AG | 1 | 312.001 | 75915 | 2110-0001 | 5 |
| | Power Cord | 1 | | 28480 | 8120-1384 | |
| | Packing Carton | 1 | | 28480 | 9211-1196 | |
| | Floater Pad, Carton | 2 | | 28480 | 9220-1409 | |
| | OPTION 008: | | | | | |
| | 10-Turn Current Control | 1 | | 28480 | 2100-1864 | |
| | var. ww 1K Ω \pm 5% 2W, 10-Turn Knob | 1 | | 28480 | 0370-1099 | |
| | OPTION 013: | | | | | |
| | 3-Digit Decadial Voltage Control | 1 | | 28480 | 1140-0020 | |
| | OPTION 014: | | | | | |
| | var. ww 1K Ω \pm 5% 2W, 10-Turn | 1 | | 28480 | 2100-1864 | |
| | 3-Digit Decadial Voltage Control | 1 | | 28480 | 1140-0020 | |

SECTION VII CIRCUIT DIAGRAMS AND COMPONENT LOCATION DIAGRAMS

7-1 INTRODUCTION

7-2 This section contains circuit diagrams necessary for the operation and maintenance of Models 6104A, 6105A, 6114A and 6115A.

7-3 COMPONENT LOCATION DIAGRAMS

7-4 The component location diagrams in Figure 7-1, 7-2, and 7-3 show the physical location of parts mounted on each assembly. The three diagrams cover the following areas:

Figure 7-1: Power Supply Board A1, Heat Sink Assembly Components, and Chassis Mounted Components

Figure 7-2: Control Board A2

Figure 7-3: Resistor Board A3 (Used on Models 6114A and 6115A only).

7-5 SCHEMATIC DIAGRAM

7-6 The four precision power supply models are covered on two schematics, Figures 7-4 and 7-5. Figure 7-4 covers models 6104A and 6105A; Figure 7-5 covers models 6114A and 6115A. Component differences between the two models covered on the same schematic are identified by code symbols \square and Δ , as follows:

Figure 7-4: \square = 6104A; Δ = 6105A

Figure 7-5: \square = 6114A; Δ = 6115A

7-7 Test points (encircled numbers) appear on the schematic diagrams. These points coincide with test points on the component location diagrams.

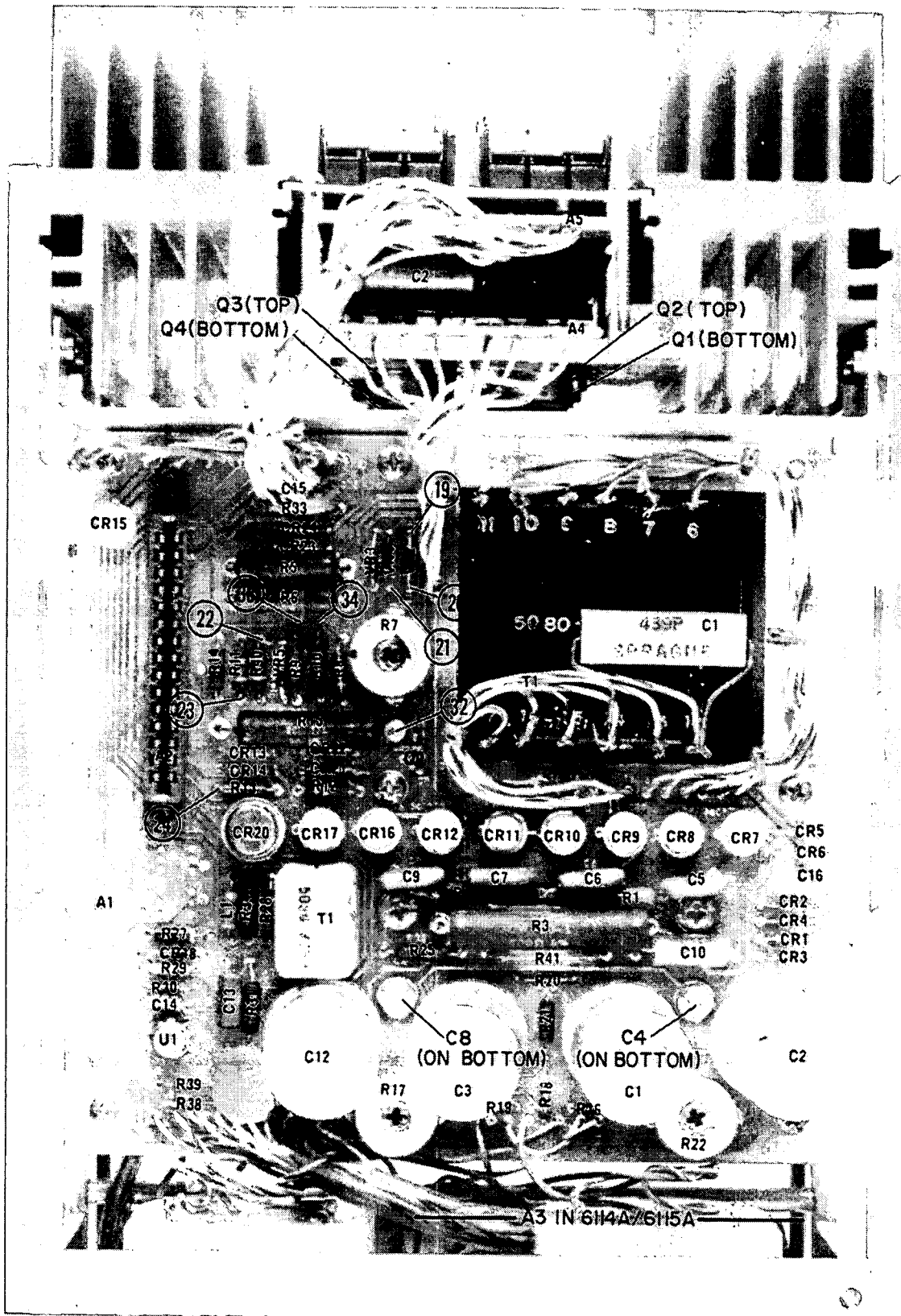

Figure 7-1. A1 Power Supply Board, Heat Sink Components, and Chassis Components, Component Location Diagram

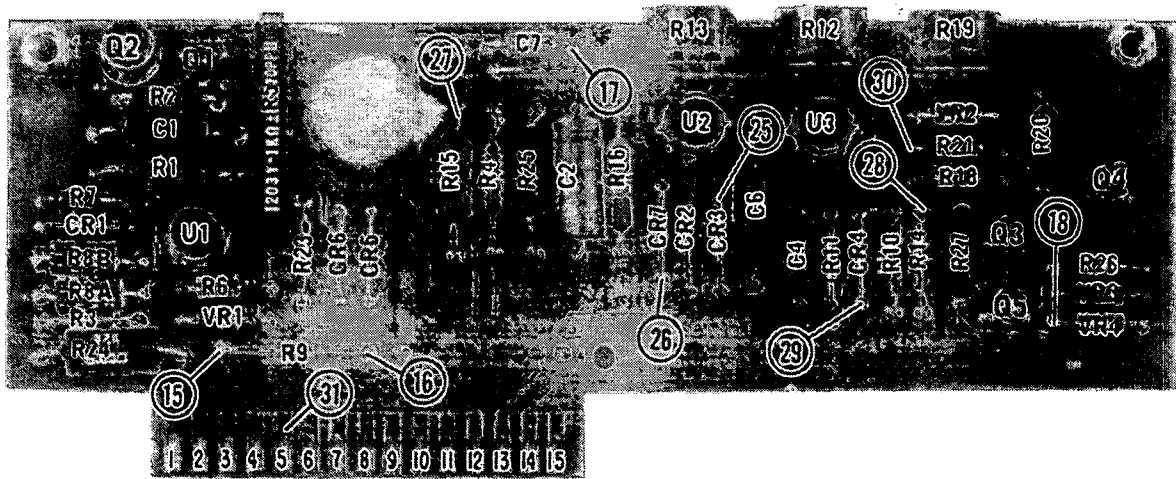

Figure 7-2. A2 Control Board, Component Location Diagram

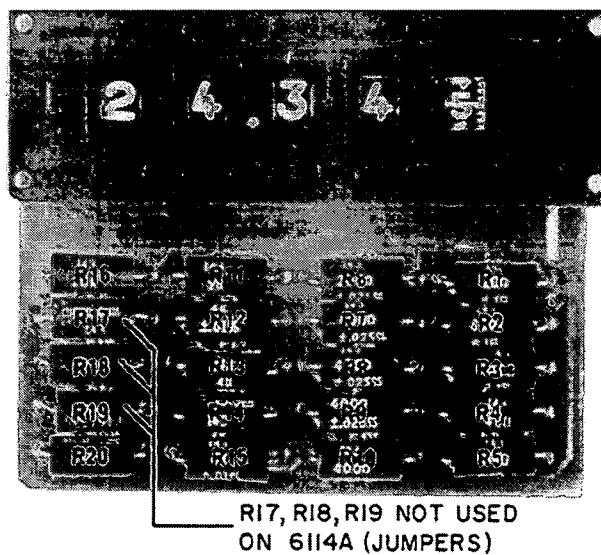
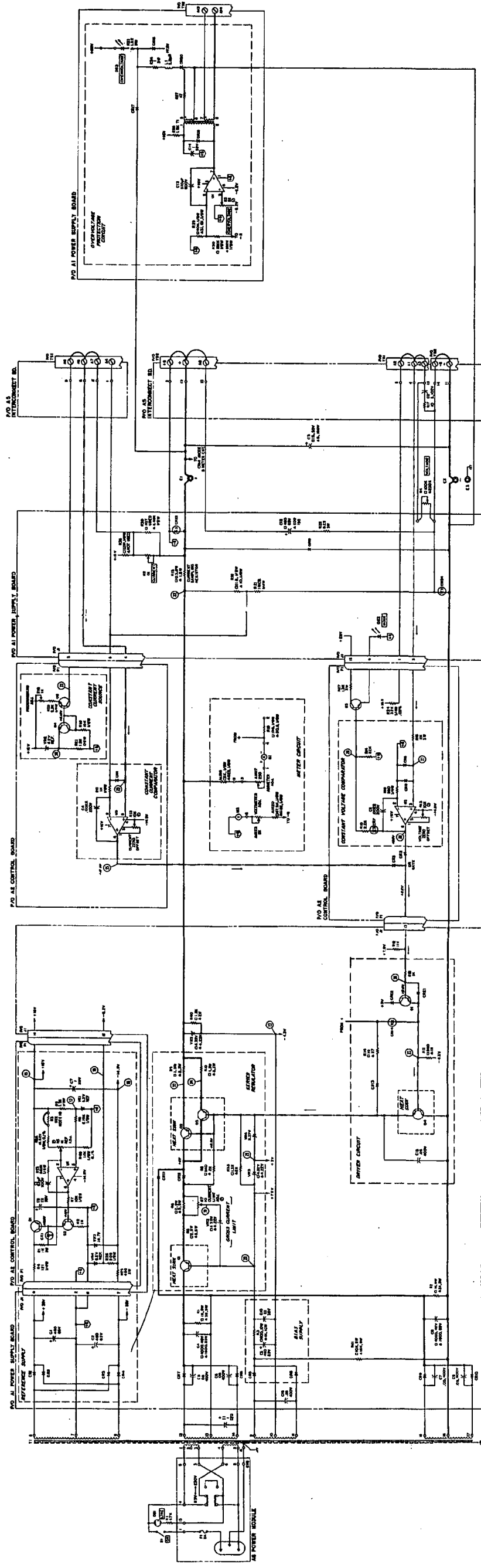

Figure 7-3. A3 Resistor Board (Used on 6114A/6115A only), Component Location Diagram



NOTE: 1. DIMENSIONS ARE IN INCHES UNLESS OTHERWISE SPECIFIED.
 2. ALL DIMENSIONS ARE TO CENTER UNLESS OTHERWISE SPECIFIED.
 3. ALL DIMENSIONS ARE TO CENTER UNLESS OTHERWISE SPECIFIED.
 4. ALL DIMENSIONS ARE TO CENTER UNLESS OTHERWISE SPECIFIED.
 5. DIMENSIONS ARE TO CENTER UNLESS OTHERWISE SPECIFIED.
 6. DIMENSIONS ARE TO CENTER UNLESS OTHERWISE SPECIFIED.
 7. DIMENSIONS ARE TO CENTER UNLESS OTHERWISE SPECIFIED.
 8. DIMENSIONS ARE TO CENTER UNLESS OTHERWISE SPECIFIED.
 9. DIMENSIONS ARE TO CENTER UNLESS OTHERWISE SPECIFIED.
 10. DIMENSIONS ARE TO CENTER UNLESS OTHERWISE SPECIFIED.
 11. DIMENSIONS ARE TO CENTER UNLESS OTHERWISE SPECIFIED.

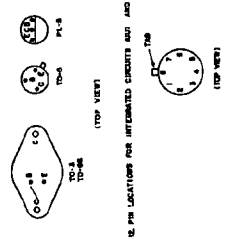

Figure 7-4. Models 6104A and 6105A, Schematic Diagram

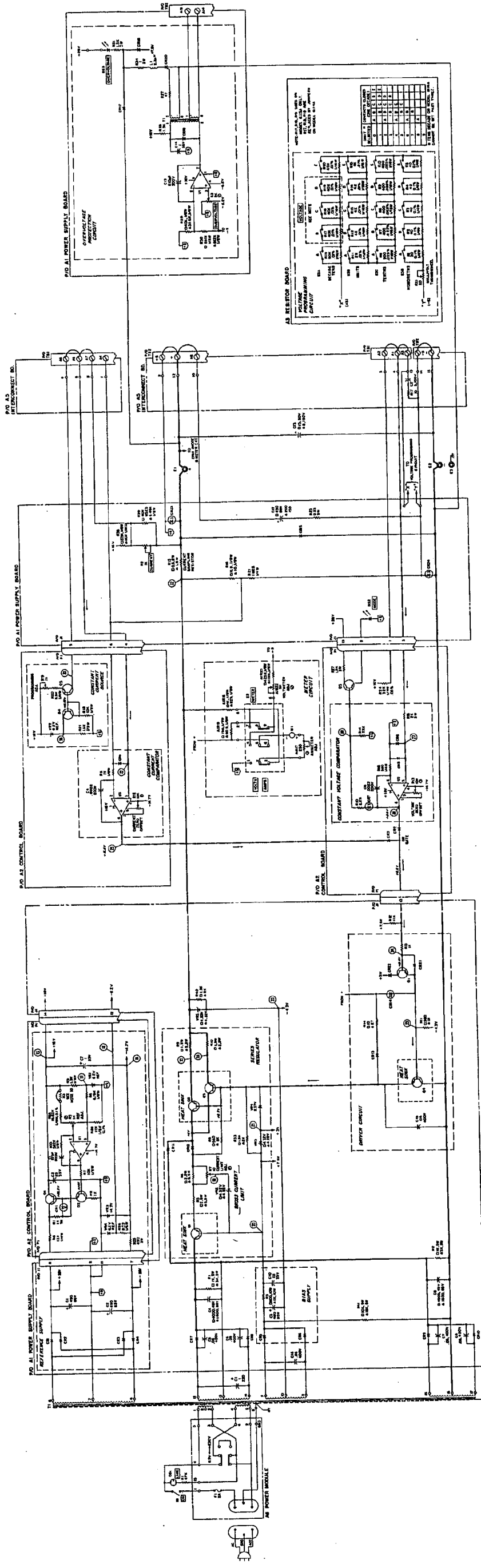

Figure 7-5. Models 6114A and 6115A, Schematic Diagram



NOTES:

1. ALL COMPONENTS ARE TO BE USED UNLESS OTHERWISE INDICATED.
2. ALL RESISTORS ARE IN OHMS, UNLESS OTHERWISE INDICATED.
3. ALL CAPACITORS ARE IN MICROFARADS UNLESS OTHERWISE INDICATED.
4. ALL DIMENSIONS ARE IN MILLIMETERS UNLESS OTHERWISE INDICATED.
5. DIMENSIONS ARE IN MILLIMETERS UNLESS OTHERWISE INDICATED.
6. DIMENSIONS ARE IN MILLIMETERS UNLESS OTHERWISE INDICATED.
7. DIMENSIONS ARE IN MILLIMETERS UNLESS OTHERWISE INDICATED.
8. DIMENSIONS ARE IN MILLIMETERS UNLESS OTHERWISE INDICATED.
9. DIMENSIONS ARE IN MILLIMETERS UNLESS OTHERWISE INDICATED.
10. DIMENSIONS ARE IN MILLIMETERS UNLESS OTHERWISE INDICATED.
11. DIMENSIONS ARE IN MILLIMETERS UNLESS OTHERWISE INDICATED.
12. DIMENSIONS ARE IN MILLIMETERS UNLESS OTHERWISE INDICATED.

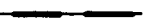

2. PIN LOCATIONS FOR INTEGRATED CIRCUITS 101 AND 102 ARE AS FOLLOWS:

NOTES:

1. □ DENOTES VALUE OF COMPONENT USED FOR MODEL 6104A ONLY.
 △ DENOTES VALUE OF COMPONENT USED FOR MODEL 6105A ONLY.
2. ALL RESISTORS ARE IN OHMS, 1/2W, ±5% UNLESS OTHERWISE INDICATED.
3. ALL 1/4W AND 1/8W RESISTORS ARE ±1%, UNLESS OTHERWISE INDICATED.
4. ALL CAPACITORS ARE IN MICROFARADS UNLESS OTHERWISE INDICATED.
5.  DENOTES CURRENT FEEDBACK PATH.
6.  DENOTES VOLTAGE FEEDBACK PATH.
7.  DENOTES FRONT PANEL MARKING.
8. D C VOLTAGES WERE MEASURED UNDER THE FOLLOWING CONDITIONS:
 - A. HEWLETT-PACKARD 427A OR EQUIVALENT.
 - B. 115VAC INPUT
 - C. SUPPLY IN CONSTANT VOLTAGE OPERATION AT MAXIMUM RATED OUTPUT VOLTAGE WITH NO LOAD CONNECTED.
 - D. CURRENT CONTROLS AND CROWBAR ADJUST CONTROLS TURNED FULLY CLOCKWISE.
 - E. VOLTAGES REFERENCED TO +S UNLESS OTHERWISE NOTED.
 - F. VOLTAGES ARE TYPICAL ±10% UNLESS OTHERWISE NOTED.
9. REAR TERMINALS ARE SHOWN IN NORMAL STRAPPING FOR USE OF FRONT PANEL CONTROLS
10. R3 (SELECTED) IS EITHER 408.2Ω OR A WIRE JUMPER DEPENDING ON THE RESULTS OF CONSTANT VOLTAGE CALIBRATION PROCEDURE. REFER TO SECTION V.
11. PIN LOCATIONS FOR TRANSISTORS ARE AS FOLLOWS:

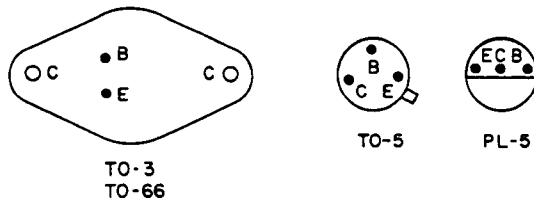

(TOP VIEW)

12. PIN LOCATIONS FOR INTEGRATED CIRCUITS A1U1 AND A2U1 THRU A2U3 ARE AS FOLLOWS:

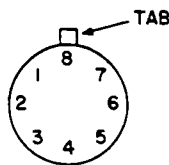

(TOP VIEW)



HEWLETT
PACKARD

5950-5976



PRINTED IN U.S.A.

